

**Friedland**

# SA3 PLUS with Telephone Dialler



**Installation & Operating Manual**

# FOREWORD

This Wirefree Alarm System has been designed to meet with the requirements of BS6799 Class 1 for Wireless Alarms. All components are designed and manufactured to provide a high standard of security protection and long, reliable service. No radio operating licence is required for this equipment. The approved radio frequency is not protected from interference, this frequency may also be used by other systems and equipment. The radio devices in this system have been tested by an independent accredited test laboratory for conformity with the R&TTE Directive for radio equipment.

The system is designed for ease of installation using only conventional domestic tools. However, it is essential that the installer reads and fully understands the advice and procedures contained in this manual and plans the system before proceeding with the installation.

During installation, it is important that the procedures described in this manual are followed in sequence.

**This manual should be retained in a safe place for future reference.**

## IMPORTANT

All components, with the exception of the External Solar Siren are suitable for mounting in dry interior locations only.

### Tools and Equipment Required:

- No.0 Philips Screwdriver
- No.1 Philips Screwdriver
- No.2 Philips Screwdriver
- 5 & 6mm Masonry Drill Bits
- Drill
- Small Spirit Level
- Bradawl

## LOCAL AUTHORITY REGULATIONS

Depending on your location within the country, you may be required, by law, to notify the Local Authorities and Police of your new alarm installation.

Local Authority requirements differ from area to area, therefore, we recommend that you contact your Local Borough Environmental Officer to obtain full details of your area's requirements.

## SYSTEM SECURITY

This system has been designed to both detect intruders and act as a strong deterrent to would-be intruders when installed correctly.

Please remember that given adequate knowledge and time it is possible to overcome any alarm system and we therefore recommend that an Intruder Alarm is used in conjunction with good physical protection such as security window and door locks.

All units in the system are encoded to operate together using an 8 bit House Code which is configured by the user/installer to provide the unique identification code for your installation. The system House Code can be changed at any time by the user.

**IMPORTANT:** All units forming part of your alarm system must be set to the same House Code.

The system is operated from the Control Panel or one or more Remote Control units (available as an upgrade accessory). Care should be taken to ensure that the User Access code for the Control Panel does not become known to other people or any Remote Control Unit(s) are not lost, as this will compromise the security of your system. In either event the system house code and User Access code should be changed as soon as possible.

## SAFETY

Always follow the manufacturers advice when using power tools; steps, ladders etc. and wear suitable protective equipment (e.g. safety goggles) when drilling holes etc.

Before drilling holes in walls, check for hidden electricity cables and water pipes, the use of a cable/pipe locator maybe advisable if in doubt.

When using ladders, ensure that they are positioned on a firm stable surface at the correct angle and suitably secured before use.

The use of ear defenders is advisable when working in close proximity to the Siren due to the high sound level produced by this device.

# CONTENTS

KIT CONTENTS	2	TESTING THE SYSTEM	18
INTRODUCTION AND OVERVIEW	3	Initial Testing	18
System Arming	3	Testing An Installed System	18
Entry/Exit Delay	3	Detector Test	18
Zones	3	Hard-Wired Siren Test	19
Zone Lockout	3	Siren Test	19
Voice Dialler	3	Control Panel LED Test	19
Tamper Protection	4	Solar Siren Service Mode	19
Jamming Detection	4	Voice Dialler Test	19
Battery Monitoring	4	FACTORY DEFAULTS	19
System House Code	4	Reset Factory Default Conditions	19
PLANNING AND EXTENDING YOUR WIREFREE		PROGRAMMING	20
SOLAR ALARM SYSTEM	5	User Access Code	20
REMOTE CONTROL	6	System House Code	20
General Information	6	Instant/Delay Zones	21
Configuring the Remote Control	6	Entry/Exit Delay	21
CONTROL PANEL	7	Alarm Duration	21
Positioning the Control Panel	7	Part-Arm	21
Installing the Control Panel	7	Zone Lockout	22
Configuring the Control Panel	9	Entry/Exit Warning Tone	22
Testing the Control Panel & Remote Control	9	Jamming Detection	22
PASSIVE INFRA-RED (PIR)		Hardwired Siren	22
MOVEMENT DETECTORS	10	Zone Operating Modes	22
Positioning the PIR Movement Detectors	10	Phone Numbers	23
Installing and Configuring the PIR		Alarm Message Play Time	23
Movement Detectors	11	Record Alarm Message	24
Testing the PIR Movement Detectors	12	Replay Alarm Message	24
MAGNETIC CONTACT DETECTORS	12	Call Routing	24
<b>(Optional Accessory)</b>		Call Attempts	24
Positioning the Magnetic Contact Detectors	13	Dial Method	24
Installing and Configuring the Magnetic		OPERATING INSTRUCTIONS	25
Contact Detectors	13	Arming The System	25
Testing the Magnetic Contact Detectors	14	Disarming The System	25
EXTERNAL SOLAR SIREN	15	Personal Attack (PA) Alarm	26
General Information	15	Tamper	26
Positioning the Solar Siren	15	Siren Service Mode	26
Installing and Configuring the Solar Siren	16	Siren Operating Mode	27
Power-up of the Solar Siren	17	Battery Monitoring	27
Testing the Solar Siren	17	MAINTENANCE	28
EXTERNAL CONNECTIONS	18	ALARM RECORD	29
		TROUBLE SHOOTING	30
		EXTENDING YOUR ALARM SYSTEM	33
		COMPONENT SPECIFICATION	Back Cover

# KIT CONTENTS

The Alarm System should contain the following components.

- 1 x External Solar Siren
- 1 x 6 Zone LED Control Panel with Telephone Dialler
- 3 x PIR Movement Detectors
- 1 x Remote Control

**Also included:**

- Power Supply Adaptor
- Telephone Connection Lead
- Installation & Operating Manual
- Fixing pack
- Batteries

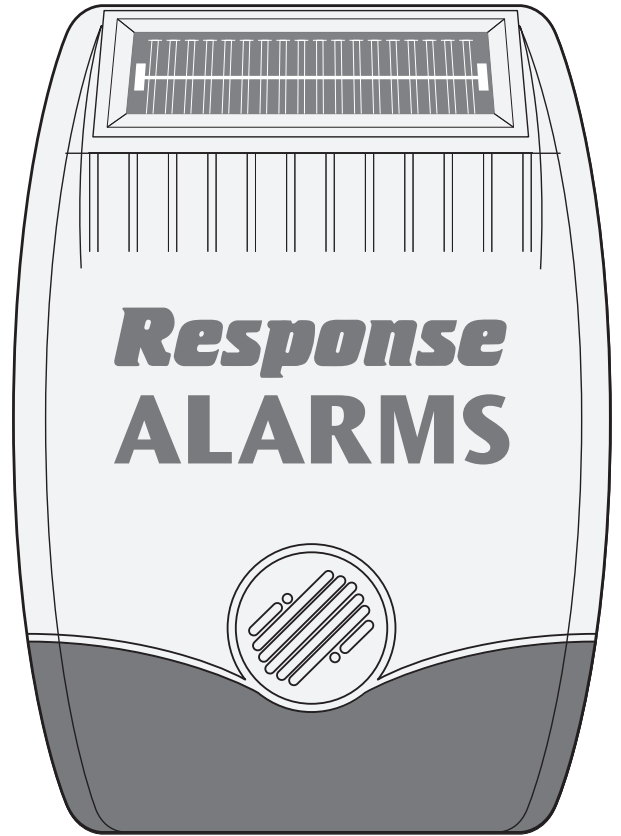

**External Solar Siren**

## IMPORTANT

Please check all items are present **BEFORE** breaking open the packaging clamshell. No claims for missing parts will be accepted unless the clamshell is unopened and intact.

## EXTENDING THE ALARM SYSTEM

The following additional accessories are available to enhance your system and provide further protection and a higher level of security where required.

<b>Component:</b>	<b>Product Code</b>
Passive Infra-Red Movement Detector	SA433P
Magnetic Contact Detector	SA433K
Remote Control	SA433R
Remote Keypad	SA433KP
Additional Solar Siren	SA433SS

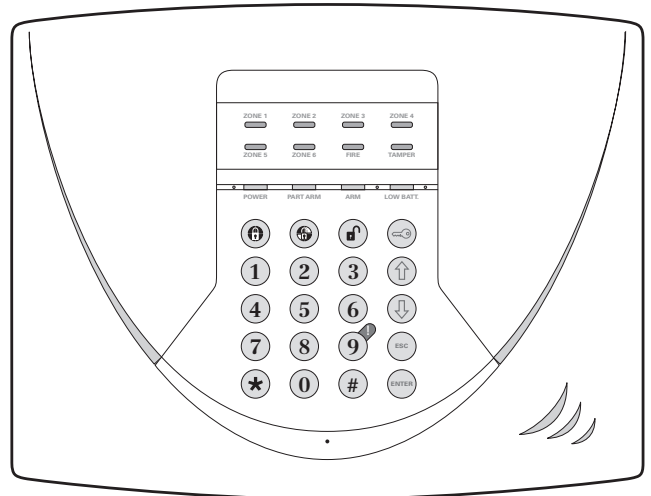

**Control Panel**

Full details of these accessories are given on page 33.

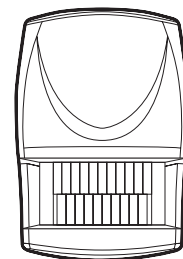

**PIR Movement Detector**

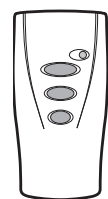

**Remote Control**

# INTRODUCTION AND OVERVIEW

## SYSTEM ARMING

The system has a full 'Arm' and a 'Part-Arm' mode. Full ARM will arm all zones while the 'Part-Arm' mode will only arm the zones that are enabled for 'Part-Arm'.

### For example:

The system could be configured such that during night time, 'Part-Arm' would arm only zones protecting the lower floor and outbuildings, leaving the upper floor free for movement without triggering the alarm.

However, when the property is left un-occupied, the full 'Arm' mode will arm all zones to protect the entire property, (i.e. upper and lower floors and outbuildings).

## ZONES

The system incorporates 6 wirefree Alarm Zones for the connection of the system detectors that are used to independently monitor different areas of the property. In addition to standard intruder protection, each zone may also be configured to operate in one of three other modes:

- 'Personal Attack' mode provides 24 hour monitoring of any Personal Attack (PA) switches incorporated into the system.
- '24-hour Intruder' mode provides 24 hour intruder protection for areas where continuous monitoring is required, (e.g. gun cupboards).
- 'Fire' mode provides 24 hour monitoring of any Fire/Smoke detectors incorporated into the system.

## ENTRY/EXIT DELAY

Each zone can be programmed to be Armed in either Instant or Delay mode.

Usually the zone covering the main entrance door and the route to and from the Control Panel would be configured in Delay mode. This allows time for the user to exit the property after setting the system at the Control Panel or to Disarm the system before an alarm condition is triggered when re-entering the property. The remaining zones would be configured as Instant allowing them to initiate an alarm immediately a detector on the zone is triggered.

Delay Armed zones will not become fully armed until after the Entry/Exit delay period has expired. When a detector on a Delay Armed zone is triggered, an alarm condition will not be triggered until after the Entry/Exit period has elapsed. If the system is not disarmed during the delay period, an alarm condition will occur when the delay period expires.

Instant Armed zones are immediately able to initiate an alarm as soon as the system begins to arm.

## ZONE LOCKOUT

If a detector on an active zone is triggered while the system is armed, an alarm condition will occur. After the programmed alarm duration has expired the alarm will stop and the system will automatically reset. Subsequent detectors triggered will again initiate an alarm condition. If a single zone initiates an alarm condition three times then that zone will be 'Locked Out' and any further alarm signals from that zone will be ignored until the system is disarmed.

**Note:** The 'Zone Lockout' feature can be disabled if required.

## VOICE DIALLER

This system incorporates a telephone voice dialler which is used to call for help and/or notify the user that the system has been triggered and an alarm has occurred.

If the Voice Dialler is enabled and an alarm condition occurs, the system will call for help using your recorded alarm message and up to four telephone numbers. When the telephone voice dialler is activated it will call the first enabled number in the dialing sequence and replay the recorded alarm messages for the configured 'Play Time'. The recipient must acknowledge the message by pressing the  button on their telephone keypad. If the call is unanswered or an acknowledgment signal is not received then the next active number in the dialing sequence will be called. The dialler will continue calling each number in turn until either all numbers in the sequence have been dialed the set number of times or the dialing sequence is cancelled by an acknowledged signal from the recipient.

## TAMPER PROTECTION

All system devices (except any Remote Control Units) incorporate Tamper protection features to protect against unauthorised attempts to interfere with the device. Any attempt to remove the battery cover from any device (except a Remote Control) or to remove the Solar Siren or Control Panel from the wall will initiate an alarm condition (unless the system is in Test or Programming modes), even if the system is Disarmed.

## JAMMING DETECTION

In order to detect any attempts to illegally jam the radio channel used by your alarm system, a special jamming detection function is incorporated into the Control Panel and Solar Siren. If this feature is enabled, and the radio channel is jammed continuously for 30 seconds, when the system is armed, the Solar Siren will emit a pre-alarm series of rapid beeps for 5 seconds. If the jamming continues for a further 10 seconds or more a full alarm condition will occur. In addition if the system is jammed for more than three periods of 10 seconds in a 5 minute interval, this will also generate a Full Alarm condition. The jamming detection features in the Control Panel and Solar Siren operate independently.

The Jamming Detection circuit is designed to permanently scan for jamming signals. However, it is possible that it may detect other local radio interference operating legally or illegally on the same frequency. If it is planned to operate the jamming detection feature we recommend that the system is monitored for false jamming alarms for at least 2 weeks prior to leaving the Jamming Detection function permanently enabled.

## BATTERY MONITORING

In addition to the battery monitor and low-battery indicators in each device, the Control Panel will also indicate a low battery status within any Passive Infra-Red or Magnetic Contact Detector on the system.

## SYSTEM HOUSE CODE

In order to prevent any unauthorised attempt to operate or disarm your system, you must configure your system to accept radio signals only from your own system devices. This is done by setting a series of eight miniature (DIP) switches in all devices (except the

Control Panel) to the same ON/OFF combination (the House Code) selected by the user/installer. The Control Panel is then programmed to operate only with devices set to this House Code. All detectors and Remote Control Unit(s) must be configured with the same House Code in order for the system to operate correctly.

Inside the Siren, Detectors and Remote Control Unit is a series of 8 DIP switches.



The House Code is set up by moving each of the 8 switches in each device to the same randomly selected ON/OFF sequence. When setting the DIP switches, ensure that each switch 'clicks' fully into position. Use the tip of a ballpoint pen or a small screwdriver to move each switch in turn.

**Note:** It is recommended that the system House Code is always reset to a code other than the factory default.

# PLANNING AND EXTENDING YOUR WIREFREE ALARM SYSTEM

The following example below shows a typical property incorporating the suggested positions for the External Siren, Control Panel, PIR and Magnetic Detectors for

optimum security. Use this as a guide for your installation in conjunction with the recommendations contained in this manual for planning your intruder alarm system.

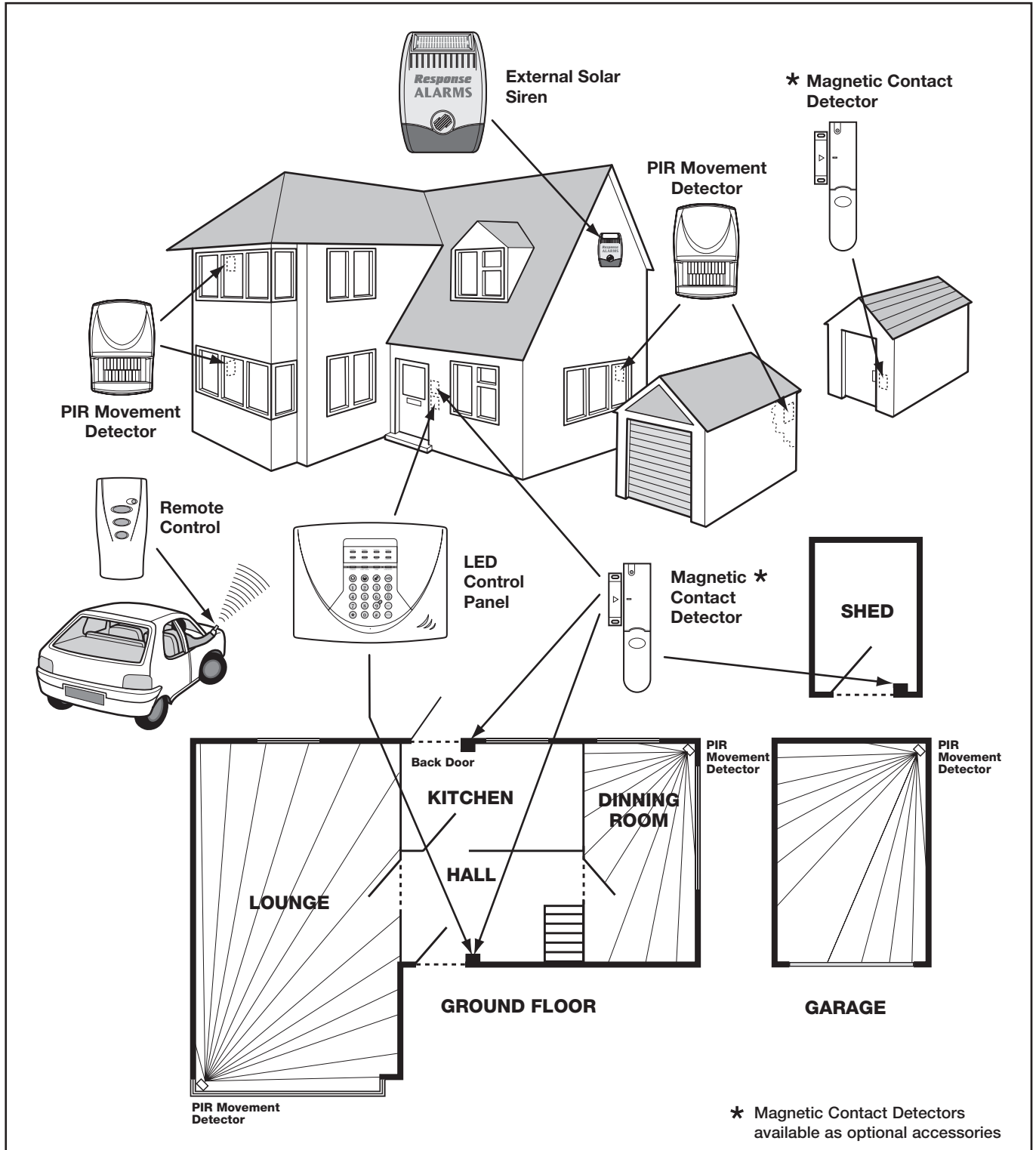

Before attempting to install your Alarm System it is important to study your security requirements and plan your installation.

The alarm system may be extended to provide even greater protection by fitting additional PIR Movement Detectors and Magnetic Contact Detectors as required.

# REMOTE CONTROL UNIT

The Remote Control Unit(s) are used to Arm, Part-Arm and Disarm the system.

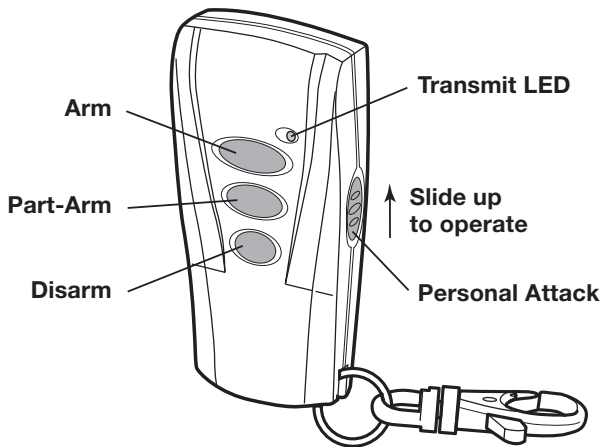

The Remote Control Unit also incorporates a Personal Attack (PA) switch. Activating the PA switch on the side of the Remote Control will immediately trigger an alarm (unless the Control Panel is in Test or Program Modes) even if the system is disarmed. The alarm can be cancelled by pressing the 'DISARM' button on the Remote Control or via the Control Panel.

Any number of Remote Control Units can be used with your system, providing they are all coded with the system House Code (DIP switch settings).

The Remote Control is powered by a CR2032 type Lithium cell which under normal conditions will have an expected life in excess of 1 year. Under normal battery conditions the LED on the Remote Control will only illuminate when a button is pressed. However, under low-battery conditions this LED will continue to flash after the button has been released. When this occurs the battery should be replaced as soon as possible.

## CONFIGURING THE REMOTE CONTROL

1. Remove the rear cover by undoing the small screw on the rear of the Remote Control and keeping it safe for later.
2. Select and record (in the Alarm Record section of this manual) a random combination of 'ON' and 'OFF' positions for the DIP switches. This will become the system House Code that enables all devices to communicate with the Control Panel.

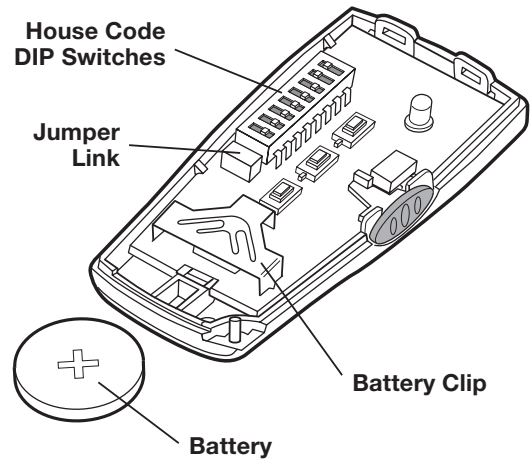

**IMPORTANT:** The House Code for your system should be changed from the factory default setting.

3. Ensure that the Jumper Link located immediately below the House Code DIP switches is fitted in position for use with this alarm system.
4. Insert the battery under the clip ensuring that the + terminal faces upwards away from the Circuit Board.



5. Replace the rear cover and fixing screw. Do not over tighten the screw as this could damage the thread.

### Testing the Remote Control:

6. Press the  button. The Transmit LED should illuminate while the button is pressed and extinguish within 1 second of releasing the button.
7. Press the  and  buttons in turn to ensure that the Transmit LED illuminates as before.



# CONTROL PANEL

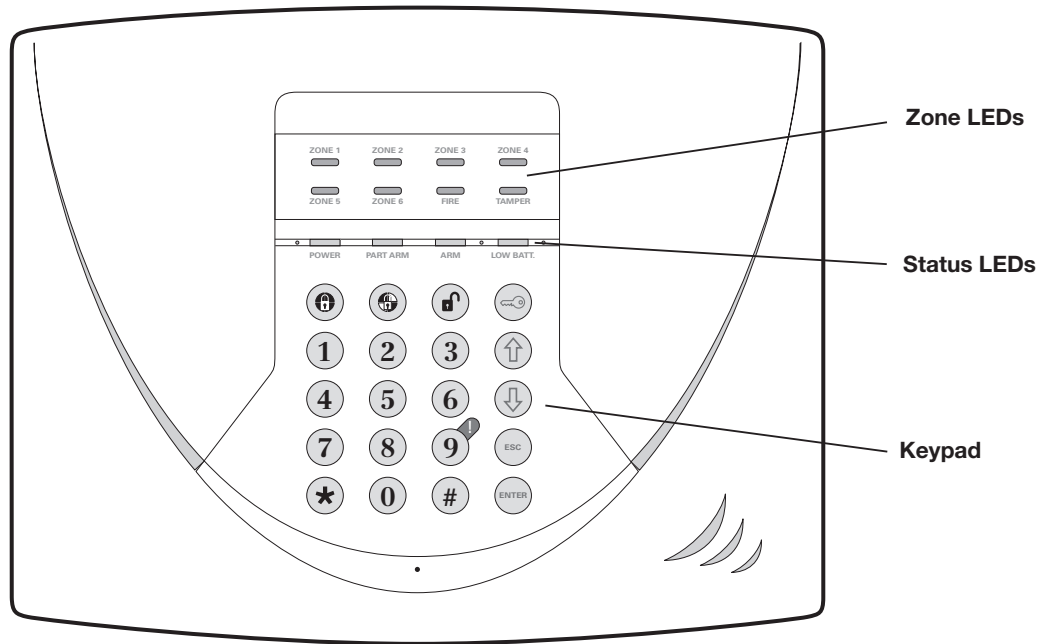

**Outside View of Control Panel**

## POSITIONING THE CONTROL PANEL

When choosing a suitable location for the Control Panel, the following points should be considered.

1. The Control Panel should be located in a position out of sight of potential intruders and in a safe location, but easily accessible for system operation.
2. The Control Panel should be mounted on a sound flat surface to ensure that the rear tamper switch on the Control Panel is closed when the Panel is mounted. The Control Panel should be mounted at a convenient height of between 1.5 and 2m and in a position where it will be seen each day.

**Note:** If small children are in the household, a further consideration should be given to keeping the units out of their reach.

3. It is recommended that the Control Panel should be positioned such that the Exit/Entry tone (emitted by the Control Panel) can be heard from outside the property.
4. The Control Panel should be mounted within a protected area so that any intruder cannot reach the Control Panel without opening a protected door or passing through an area protected by a PIR movement detector when the system is armed.

5. The Control Panel must be located within reach of a mains socket.
6. If the telephone voice dialler is to be used then the Control Panel will need connecting to a convenient telephone point.
7. Do not locate the Control Unit closer than 1m to any large metallic object, (e.g. mirrors, radiators, etc) as this may affect the radio range of the Control Panel.

## INSTALLING THE CONTROL PANEL

1. Undo the two captive fixing screws on top of the panel and open the cover. The cover is hinged along the bottom edge.
2. Unclip and remove the two back-up batteries on either side of the panel.
3. Hold the Control Panel in position on the wall and mark the positions of the four fixing holes. Remove the Panel and drill four 5mm holes and fit the 25mm Wall Plugs.

**Note:** The wall plugs supplied with the product are not suitable for plasterboard walls, if mounting the Control Panel onto plasterboard use proprietary wall plugs.

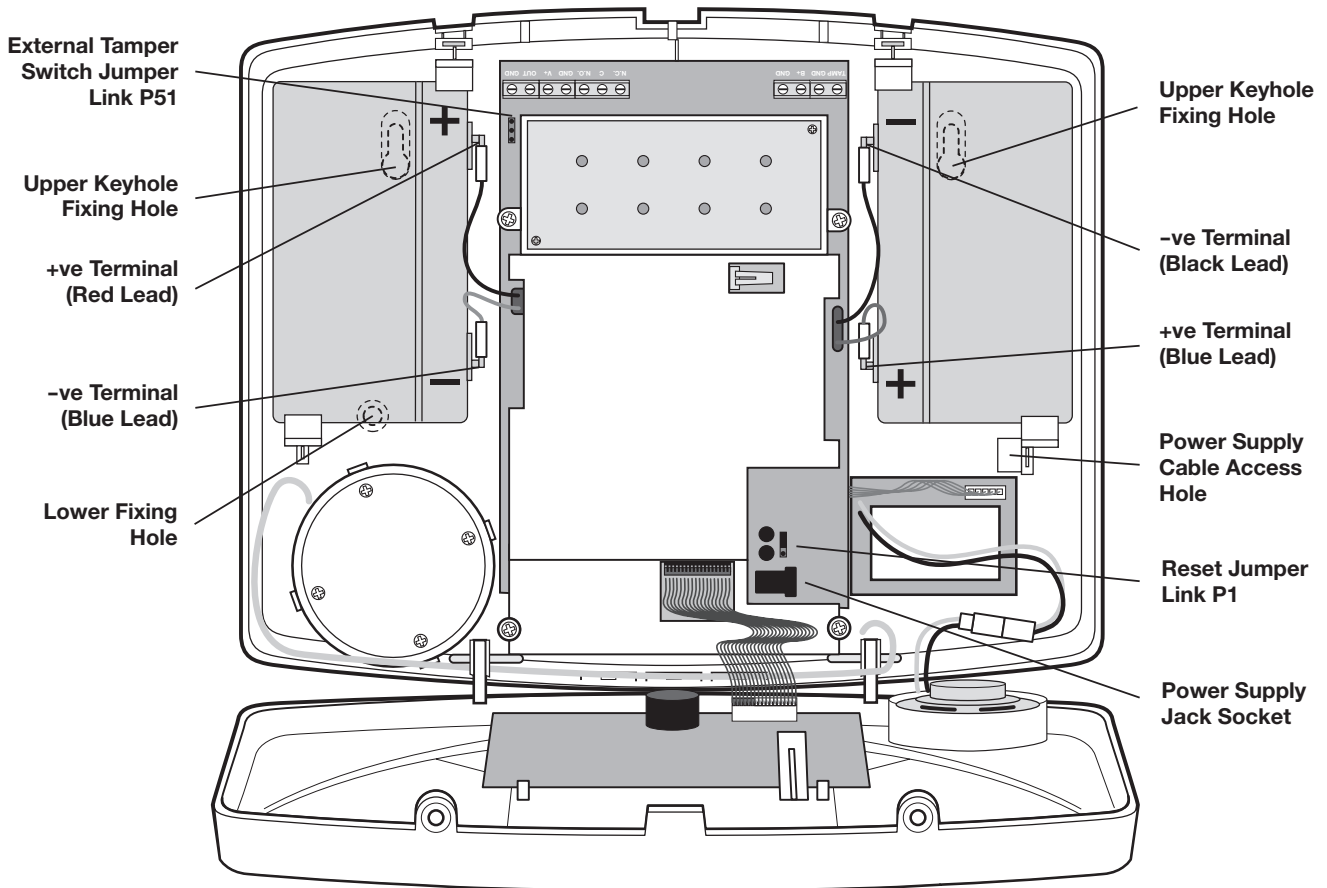

**Inside View of Control Panel**

**IMPORTANT:** Do not drill the fixing holes with the Control Panel in position; as the resulting dust and vibration may damage the Control Panel's internal components and invalidate the guarantee.

4. Fit two 18mm No.4 screws into the top holes until almost fully home and hang the Control panel over these screws using the two keyhole slots in the top corners of the panel casing.
5. Route the cable from the Power Supply Unit up behind and on the right hand side of the Control Panel and connect the plug to the DC power socket in the panel. Ensuring that the cable is not trapped between the panel and the wall.
6. Fix the Panel to the wall using two 18mm No.4 screws in the lower two fixing holes in the panel and tighten the upper fixing screws until they just grip the casing. Do not over tighten the fixing screws as this could damage or distort the casing.
7. Ensure that the "Reset" and the "Hard-Wired Siren tamper detect" jumper links are set in the OFF position.

8. Connect battery leads to both back-up batteries and refit batteries.

Battery 1 (left): Red lead to **+ve** battery terminal  
Blue lead to **-ve** battery terminal

Battery 2 (right): Blue lead to **+ve** battery terminal  
Black lead to **-ve** battery terminal

**IMPORTANT:** Take care when connecting battery leads to the batteries as connecting incorrectly could damage the batteries or the Control Panel.

**Note:** The Power LED may flash to indicate that the unit is being operated from the back-up batteries and that mains supply is not present.

9. Close the lid of the Control Panel and tighten the captive fixing screws.
10. Plug in and switch ON the Power Supply Unit, (the Power LED should illuminate).
11. If required, connect the Control Panel to the telephone line using the cable supplied by inserting small RJ11 plug into socket marked LINE located on the bottom edge of the Control Panel.

Connect the BT plug on the other end of the lead to an appropriate telephone outlet.

If the cable supplied is not long enough to reach a suitable phone point then it will need extending using a coupler and extension lead (not supplied).

**Note:** If the Panel Tamper alarm sounds during the installation reset the alarm by pressing:



on the Control Panel Keypad.

## CONFIGURING THE CONTROL PANEL HOUSE CODE

**With unit in Standby mode (Power LED only illuminated).**

1. Press



The Control Panel will beep twice and the Arm and Part-Arm LEDs will illuminate. All Zone, Fire and Tamper LEDs will flash.

This puts the Control Panel into programming mode.

2. Press  , 

The Zone LEDs 1-6, Fire and Tamper LEDs will illuminate to indicate the current House Code setting with an illuminated LED indicating a setting of "1" in the House Code and LEDs which are OFF indicating a "0".

**For Example:** A house code of 11110010, will be indicated with zone LEDs 1-4 ON and 5-6 OFF, Fire LED ON and Tamper LED OFF.

3. The system House Code can be programmed either directly at the Control Panel or via a Remote Control Unit:

**At the Control Panel:**

a) By pressing buttons 1-8 on the Control Panel, configure the status LEDs so that they indicate the required house code setting. The LEDs will switch to the opposite state each time the button is pressed.

LED ON = 1, (House Code DIP Switch On/Up)

LED OFF = 0, (House Code DIP Switch Off/Down)

b) Press  to save the new setting and return to programming mode.

c) Press  to return to programming mode without saving.

**Using a Remote Control Unit:**

a) With the required House Code already configured, press the  button on the Remote Control.

The Control Panel will beep twice to acknowledge the signal.

The Zone, Fire and Tamper LED status will be updated to correspond with the House Code set on the Remote Control and now programmed into the Control Panel.

b) Press  to return to programming mode.

4. Press  to exit programming mode and return to Standby.

5. Press  ,     , 

The Control Panel will beep and the Arm and Part-Arm LEDs will flash.

This puts the Control Panel into test mode

## TESTING THE CONTROL PANEL & REMOTE CONTROL

1. Arm the Panel by pressing the  button on the Remote Control.

The Zone LED will illuminate for a few seconds to indicate which zones are being armed. As the entry/ exit delay expires the Control Panel will slowly beep and the Arm LED will flash. Towards the end of the delay the beep rate will increase. When the entry/exit delay is completed the beeping will stop and the Arm LED will stop flashing and be constantly illuminated.

2. Disarm the system by pressing the  button on the Remote Control.



The Panel will beep twice and the Arm LED will turn OFF.

3. Activate the Personal Attack switch on the Remote Control.

The Control Panel alarm will sound and all Zone/Fire/Tamper LEDs will flash.

- Disarm the system by pressing the  button on the Remote Control.

The Control Panel alarm will stop. The LEDs will continue to flash.

- Press  on the Control Panel to return to Standby and cancel any warning LEDs.
- Test the range of the Remote Control by pressing the  button on the Remote Control from in and around the property and from all locations where you plan to install detectors. Check that the Control Panel acknowledges the signal from the Remote Control by beeping twice each time the  button is pressed.

Note: Wait for 10s after pressing the button before pressing it again.

- Press , , , , , 

The Control Panel will beep to acknowledge the signal and the Arm and Part-Arm LEDs will flash.

This put the Control Panel into Test mode.

## PASSIVE INFRA RED (PIR) MOVEMENT DETECTORS

PIR detectors are designed to detect movement in a protected area by detecting changes in infra-red radiation levels caused, for example, when a person moves within or across the devices field of vision. If movement is detected an alarm signal will be generated, (if the system and alarm zone is armed).

**Note:** PIR detectors will also detect animals, so ensure that pets are not permitted access to areas fitted with Passive Infra Red Movement Detectors when the system is armed.

Any number of PIR Movement Detectors can be used with your system, providing they are all coded with the system House Code and are mounted within effective radio range of the Control Panel.

The PIR Detector is powered by a PP3 Alkaline battery which under normal conditions will have an

expected life in excess of 1 year. When the battery level drops, with the PIR in normal operation mode and the battery cover fitted, the LED behind the detection window will flash. When this occurs the batteries should be replaced as soon as possible.

### POSITIONING THE PIR MOVEMENT DETECTORS

The recommended position for a PIR Movement Detector is in the corner of a room mounted at a height between 2 and 2.5m. At this height, the detector will have a maximum range of up to 12m with a field of view of 110°.

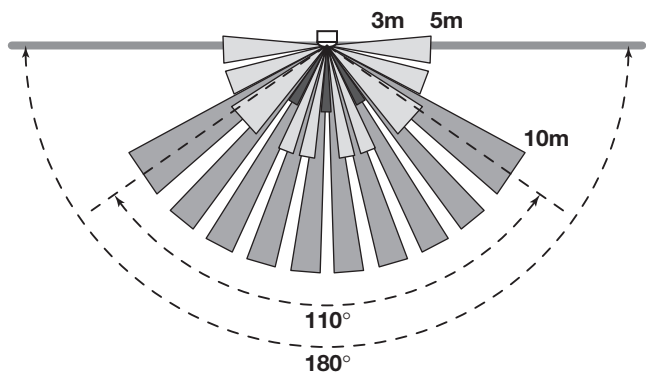
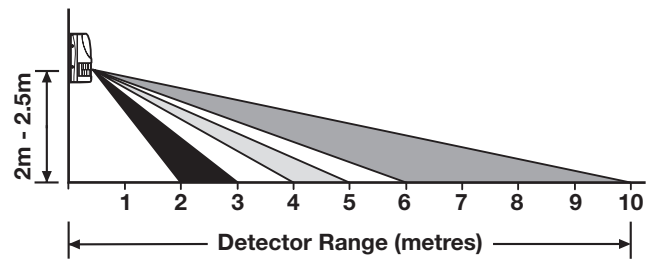

Detection Zone Pattern for PCB in position 5

The Position of the PCB inside the PIR can be set to 5 different positions to adjust the range of the detection pattern created by the PIR. Setting the PCB in position 3 will reduce the range to approximately 9m, with position 1 providing a range of approximately 6m. The recommended position setting for the PCB is in position 5.

When considering and deciding upon the mounting position for the detector the following points should be considered to ensure trouble free operation:

- Do not position the detector facing a window or where it is exposed to or facing direct sunlight. PIR Movement Detectors are not suitable for use in conservatories.
- Do not position the detector where it is exposed to draughts.
- Do not position the detector directly above a heat source, (e.g. fire, radiator, boiler, etc).

- Where possible, mount the detector in the corner of the room so that the logical path of an intruder would cut across the fan detection pattern. PIR detectors respond more effectively to movement across the device than to movement directly towards it.
- Do not position the detector in a position where it is subject to excessive vibration.
- Ensure that the position selected for the PIR detector is within effective range of the Control Panel. It is recommended that prior to installation the detector is configured and tested with the Control Panel in Walk test mode to ensure that they are within effective range.

**Note:** When the system is Armed, pets should not be allowed into an area protected by a PIR Detector as their movement would trigger the PIR and trigger an alarm.

**Note:** DO NOT fix the detector to metalwork or locate the unit within 1m of metalwork (i.e. radiators, water pipes, etc) as this could affect the radio range of the Device.

## INSTALLING AND CONFIGURING THE PIR MOVEMENT DETECTORS

Ensure that the system is in Test mode, (see page 18).

- Undo and remove the fixing screw from the bottom edge of the PIR. Carefully pull the bottom edge of the detector away from the rear cover and then slide down to release the top clips.
- Carefully drill out the required mounting holes in the rear cover using a 3mm drill according to whether the unit is being mounted in a corner or against a flat wall.

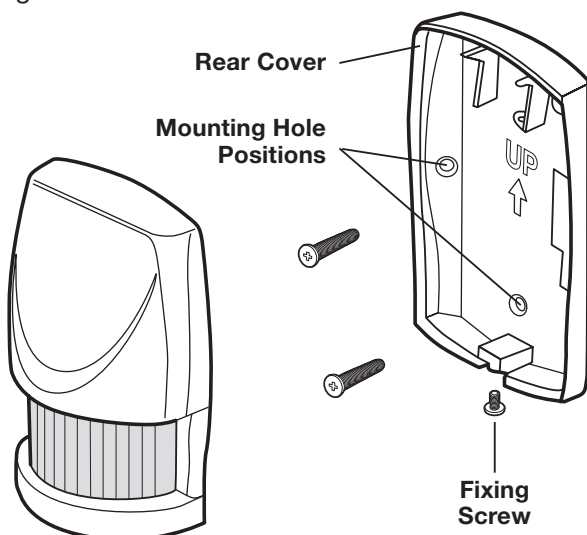

- Using the rear cover as a template, mark the positions of the fixing holes on the wall.
- Fix the rear cover to the wall using the two 18mm No.4 screws and 25mm wall plugs, (a 5mm hole will be required for the wall plugs). Do not over-tighten the fixing screws as this may distort or damage the cover.

**Note:** The wall plugs supplied with the product are not suitable for plasterboard walls, if mounting the Detector Panel onto plasterboard use proprietary wall plugs.

- Configure the House Code for the PIR Detector by setting DIP switches 1-8 of SW2 to the same ON/OFF combination as the House Code DIP switches in all other system devices.
- Configure the alarm zone which the detector will operate on by setting DIP switches 1-3 of SW3 as follows:

	DIP 1	DIP 2	DIP 3
Zone 1	OFF	OFF	OFF
Zone 2	OFF	OFF	ON
Zone 3	OFF	ON	OFF
Zone 4	OFF	ON	ON
Zone 5	ON	OFF	OFF
Zone 6	ON	OFF	ON

- DIP 4 of SW3 is used to configure the PIR Detector for walk test mode, which allows the operation of the detector to be checked during installation without triggering a Full Alarm.

ON      Walk Test mode  
 OFF     Normal operation

**Note:** On initial installation the detector should be configured into Walk-Test mode ready for testing.

- The PIR Detector incorporates an anti-false alarm feature designed to compensate for situations where the detector may be affected by environmental changes, (e.g. insects, air temperature, etc). This feature is called "Pulse Count" and may be selected for 1 or 2 pulse detection.

The recommended setting is for 1 pulse detection. However, in cases of extreme environmental problems or if unattributable false alarms are experienced, it may be necessary to select 2 pulse detection.

To select the required pulse count set DIP 5 of SW3 as follows:

- ON 1 pulse detection
- OFF 2 pulse detection

**Note:** The higher the Pulse Count the more movement will be necessary before the PIR detector will trigger the alarm.

9. Connect the PP3 Alkaline battery to the battery clip.

**Note:** When the 9V Alkaline battery is connected the LED behind the lens will rapidly flash for approximately 2-3 minutes until the PIR has warmed-up and stabilised. The LED will then stop flashing and turn OFF.

10. Check that the detector PCB is located and set in the correct position to give the detection zone pattern required.

To adjust the PCB position simply slide it up or down ensuring that the location legs are aligned with the required position number marked on the board.

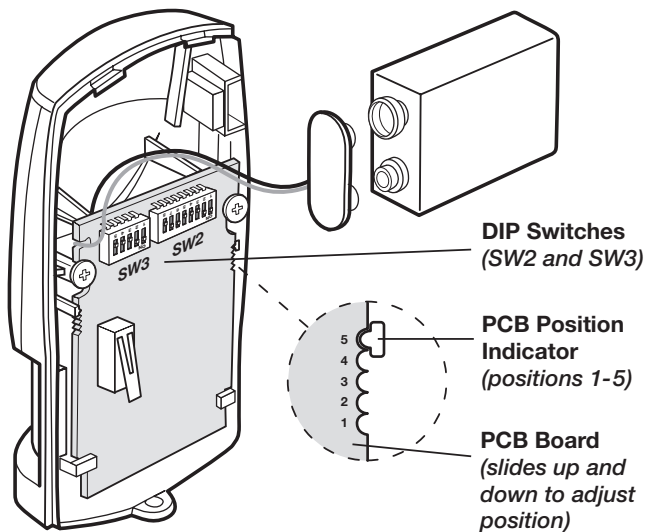

PCB Position	Range
1	6m
3	9m
5	12m

11. Refit the PIR detector to the rear cover by offering the detector up to the rear cover and locate the clips in the top edge into the rear cover. Push the lower edge of the detector into place and refit the fixing screw in the bottom edge of the PIR to secure in position. Do not over-tighten the fixing screws as this may damage the casing.

## TESTING THE PIR MOVEMENT DETECTORS

**Ensure that the system is in Test mode, (see page 18).**

Ensure that the PIR is configured in Walk Test mode, (i.e. DIP 4 of SW3 ON) and mounted in position on the wall.

Allow 2-3 minutes for the detector to stabilise before commencing testing.

1. Put the Control Panel into "Walk Test" mode by pressing **1** on the Control Panel.

The Panel will beep and the Zone 1 LED will illuminate.

2. Walk into and move slowly around the protected area, each time the detector senses movement the LED behind the lens will flash. In addition, the Control Panel will beep twice to indicate that the alarm signal has been received and the appropriate zone LED which the detector is configured for will illuminate.

**Note:** In normal operation, the LED will not flash on movement detection. If necessary re-adjust the detection pattern by changing the mounting position of the PCB within the PIR housing.

3. Press **ESC** on the Control Panel to exit Walk Test mode.

4. Reconfigure the PIR Detector into Normal operation mode and refit in position.

**Note:** When the detector is fully installed i.e. battery cover is refitted; the unit will not detect movement for approximately 45 seconds after each activation. (This feature is present to conserve battery power and maximise the battery life).

## MAGNETIC CONTACT DETECTOR(S)

**OPTIONAL ACCESSORY - See page 30 for details of accessories available.**

The Magnetic Contact Set comprises two parts; a Detector and a Magnet. They are designed to be fitted to either doors or windows with the Magnet screwed to the moving/opening part and the Contact screwed to the fixed door or window frame.

When the protected door or window is closed the Detector Contact Switch is held closed by the Magnetic field from the Magnet. Opening the protected door or window will remove the magnetic field and allow the Contact Detector Switch to open generating an alarm signal, (if the system and alarm zone is armed).

The Magnetic Contact Detector has the facility to connect an additional wired Magnetic Contact. This additional contact must be of a normally closed contact type with the contacts being opened in order to generate an alarm condition.

Any number of Magnetic Contact Detectors can be used with the system, providing they are all coded with the system House Code and are mounted within effective radio range of the Control Panel.

The Magnetic Contact Detector is powered by two CR2032 type Lithium cells which under normal conditions will have an expected life in excess of 1 year. Under normal battery conditions the LED on the Detector will not illuminate when the Detector is triggered, (unless in test mode). However, under low-battery conditions this LED will be illuminated for approximately 1s when the detector is triggered. When this occurs the batteries should be replaced as soon as possible.

## POSITIONING THE MAGNETIC CONTACT DETECTORS

The Magnetic Contact Detector is suitable for mounting in dry interior locations only.

Decide which doors and windows are to be protected by fitting Magnetic Contact Detectors, (usually the front and back doors as a minimum will have Magnetic Contact Detectors fitted). However additional detectors may be fitted where required to other more vulnerable doors or windows, (e.g. garage, patio/conservatory doors etc).

Ensure that the position selected for the Magnetic Contact detector is within effective range of the Control Panel. It is recommended that prior to installation the detector is configured and tested with the Control Panel in Walk test mode to ensure that they are within effective range.

**Note:** Take care when fixing the Detector to a metal frame, or mounting within 1m of metalwork (i.e. radiators, water pipes, etc) as this could affect the

radio range of the device. If required, it may be necessary to space the magnet and detector away from the metal surface using a plastic or wooden spacer to achieve the necessary radio range.

## INSTALLING AND CONFIGURING THE MAGNETIC CONTACT DETECTORS

**Ensure that the system is in Test mode, (see page 18).**

1. Remove the battery cover by sliding and lifting it off. (DO NOT use a screwdriver to lever off).
2. Remove the battery holder by carefully tilting up the end and pulling the connector off of the printed circuit board.

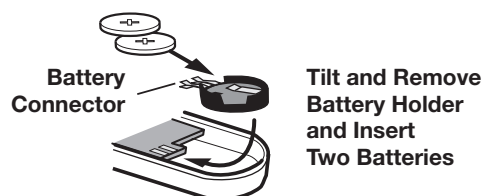
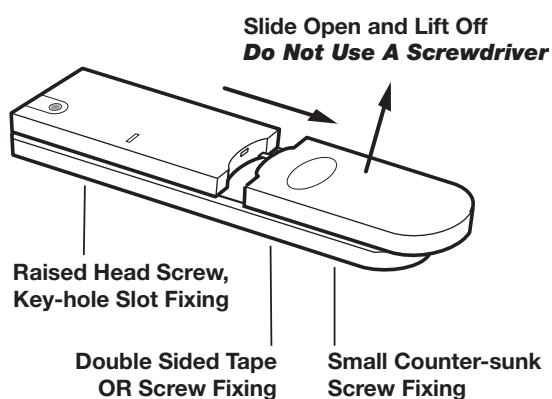

3. Mount the Detector to the fixed part of the frame along the opening edge opposite the hinges using either the double sided adhesive tape or screws provided.

When fixing the Detector with screws the top of the Detector is secured with a keyhole slot over the screw head of the smaller pan head screw. The bottom is secured using the 12mm countersunk head screw fitted within the battery compartment. Carefully drill out the centre of the fixing screw hole in the battery compartment using a 3mm drill. Do not over-tighten the fixing screws as this may distort or damage the casing.

4. Fit the Magnet to the moving part of the door/window opposite the Detector using the two 15mm fixing screws. Ensuring that the

parallel gap between the Magnet and Detector is less than 10mm and that the arrow on the Magnet is pointing towards and aligned with the mark on the top section of the Detector.

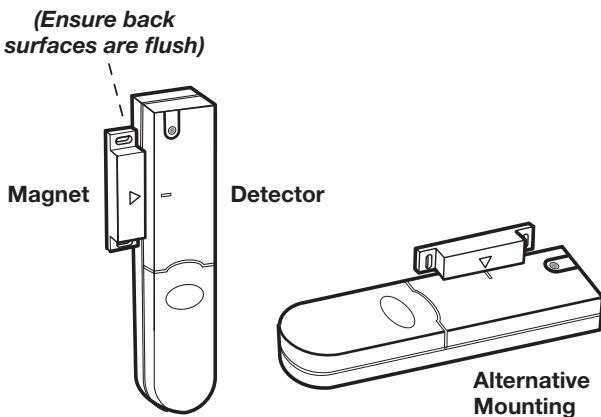

- If an additional wired Magnetic Contact is required, this should be wired to the terminal block provided in the battery compartment. The wired contact should be connected using two core (24AWG) wire of maximum length 1.5m.

If an additional wired contact is connected to the Detector then jumper link S2 on the PCB must be removed.

**IMPORTANT:** If an additional wired contact is not connected, then the jumper link SW2 must be fitted for the detector to operate correctly.

- Configure the House Code for the Magnetic Contact Detector by setting DIP switches 1-8 to the same ON/OFF combination as the House Code DIP switches in all other system devices.

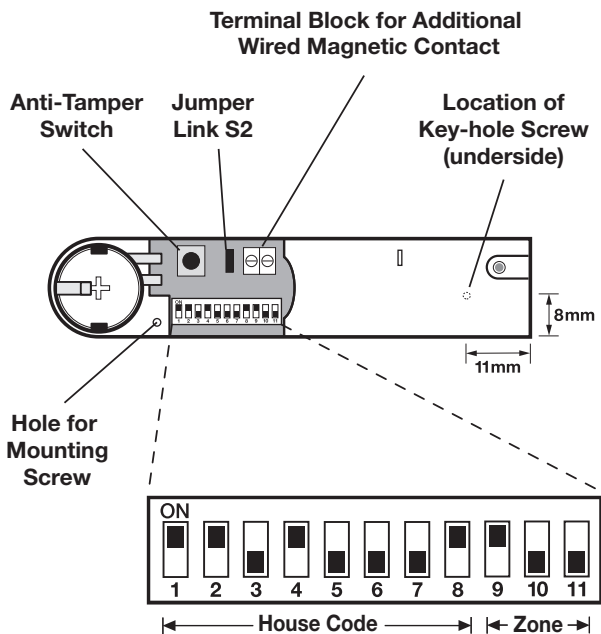

- Configure the alarm zone which the detector will operate on with DIP switches 9-11 as follows:

	DIP 9	DIP 10	DIP 11
Zone 1	OFF	OFF	OFF
Zone 2	OFF	OFF	ON
Zone 3	OFF	ON	OFF
Zone 4	OFF	ON	ON
Zone 5	ON	OFF	OFF
Zone 6	ON	OFF	ON

- Slide the batteries supplied into the battery holder, ensuring that the positive (+) side is uppermost on each battery as it is installed.
- Carefully refit the battery holder onto the Detector ensuring that the spring connectors slide onto either side of the circuit board.
- Fit the battery cover into position on the Detector.

## TESTING THE MAGNETIC CONTACT DETECTORS

Ensure that the system is in Test mode, (see page 18).

- Put the Control Panel into "Walk Test" mode by pressing **1** on the Control Panel.

The Panel will beep and the Zone 1 LED will illuminate.

- Remove the battery cover from the Detector.

The LED on the Detector will illuminate for approx. 1s as the battery cover is removed and the tamper switch is activated. In addition, the Control Panel will beep twice to indicate that the alarm signal has been received and the Tamper LED will illuminate.

- Open the door/window to remove the magnet from the Detector.

As the magnet is moved away from the detector the LED will illuminate for approximately 1s to indicate that the Detector has been triggered. In addition, the Control Panel will beep twice to indicate that the alarm signal has been received and the appropriate zone LED, which the detector is configured for, will illuminate.

- If any external Magnetic Contact Sets are connected to the Detector, operate these one at a time. Each time a contact is opened the LED on the Detector should illuminate for 1s to indicate that it has been triggered.



5. Replace the battery cover on the Detector.
6. Press  on the Control Panel to exit Walk Test mode.

## EXTERNAL SOLAR SIREN

The Siren and Solar Panel are all encapsulated within a tough polycarbonate housing. This housing provides full protection against adverse weather conditions.

An LED/Strobe unit is built into the siren to act as a visible deterrent/indication that the system is active. The Strobe LEDs will slowly and alternately flash whether the system is Armed or Disarmed. During an alarm condition the Strobe LEDs will flash rapidly.

An integral anti-tamper switch provides additional security protection to the Siren and will immediately generate a full alarm should any unauthorised attempt be made to interfere with and remove the siren cover.

The Siren is powered by a high capacity 6V/1.2Ahr rechargeable sealed lead acid battery. A Solar Panel mounted on the top of the housing charges the battery during daylight hours. During darkness, only a small amount of energy is required to operate the Siren unit.

A 9V Alkaline PP3 battery is supplied in the External Siren to boost the initial power to the unit when the system is first activated until the Solar Panel charges the main battery.

### POSITIONING THE SOLAR SIREN

The Siren should be located as high as possible in a prominent position so that it can be easily seen and heard. The Siren should be mounted on a sound flat surface so that the rear tamper switch is not activated when mounted. Ensure that the tamper switch does not fall into the recess between brick courses as this could prevent the switch from closing and give a permanent tamper signal.

To provide the optimum amount of daylight to the Solar Panel, you should ideally mount the Solar Siren on a south facing wall. However, an easterly or westerly position will suffice.

Although the Solar Siren is designed to work on any aspect wall, for optimum performance you should refrain from siting the unit on a north facing wall, where possible.

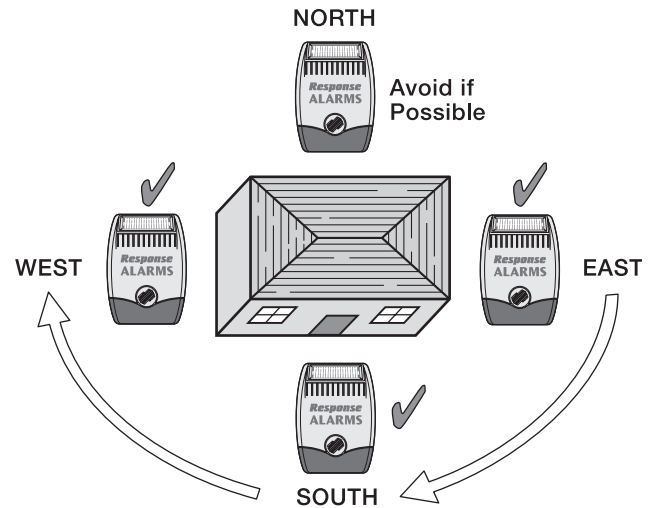

Shadows cast by neighbouring walls, trees and roof overhangs should also be avoided. If the Siren is to be mounted below the eaves, it should be positioned a distance of at least twice the width of the eaves overhang below the eaves. Remember that in winter the sun is lower in the sky and you should avoid winter shadows where possible.

The External Solar Siren contains a sophisticated radio receiver. However, reception of radio signals can be affected by the presence of metallic objects within the vicinity of the Solar Siren. It is therefore important to mount the Solar Siren a minimum distance of 1m away from any external or internal metalwork, (i.e. drainpipes, gutters, radiators, mirrors etc).

Ensure that the position selected for the Solar Siren is within effective range of the Control Panel. It is recommended that prior to installation the Solar Siren is configured and tested with the Control Panel to ensure that they are within effective range.

# INSTALLING AND CONFIGURING THE SOLAR SIREN

1. Remove the fixing screw from the bottom edge of the Siren housing and carefully hinge off the front cover. All electronic components are housed within the front cover.
2. Hold the mounting plate in position and mark the positions of the four mounting holes. A spirit level placed on the casing will ensure a perfect level. Drill four 6mm holes and fit the wall plugs.
3. Fit the two 30mm fixing screws in the top holes leaving approximately 10mm of the screw protruding.
4. Fit the top keyhole slots of the mounting plate over the screw heads. Remove the mounting plate and adjust the screws until they form a neat fit with the mounting plate with minimal movement.
5. Secure the mounting plate in position using the two 25mm fixing screws in the bottom fixing holes.
6. Ensure that the Solar Siren main configuration switch on the LED strobe board is set to "SIREN" for use with this alarm system.

7. Undo the 3 screws holding the DIP Switch Cover in place and remove the cover.
8. Under the cover you will find a series of 9 DIP switches.
 

**Note:** When the Solar Siren is viewed as shown above (Solar panel at top) the DIP switches are 'upside down'.
9. DIP switches 1-8 are used to set the House Code for the Siren and must be set to the same ON/OFF combination as all other system devices.

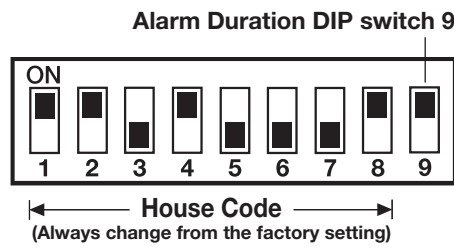

10. If required the maximum length of time that the External Solar Siren will sound for when activated under an alarm condition may be limited to 3 minutes using DIP switch 9 as follows:

OFF	3 minutes
ON	as Control Panel setting

**Main Configuration Switch (in SIREN Position)**

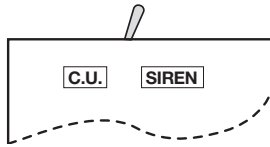

## Inside View of Siren

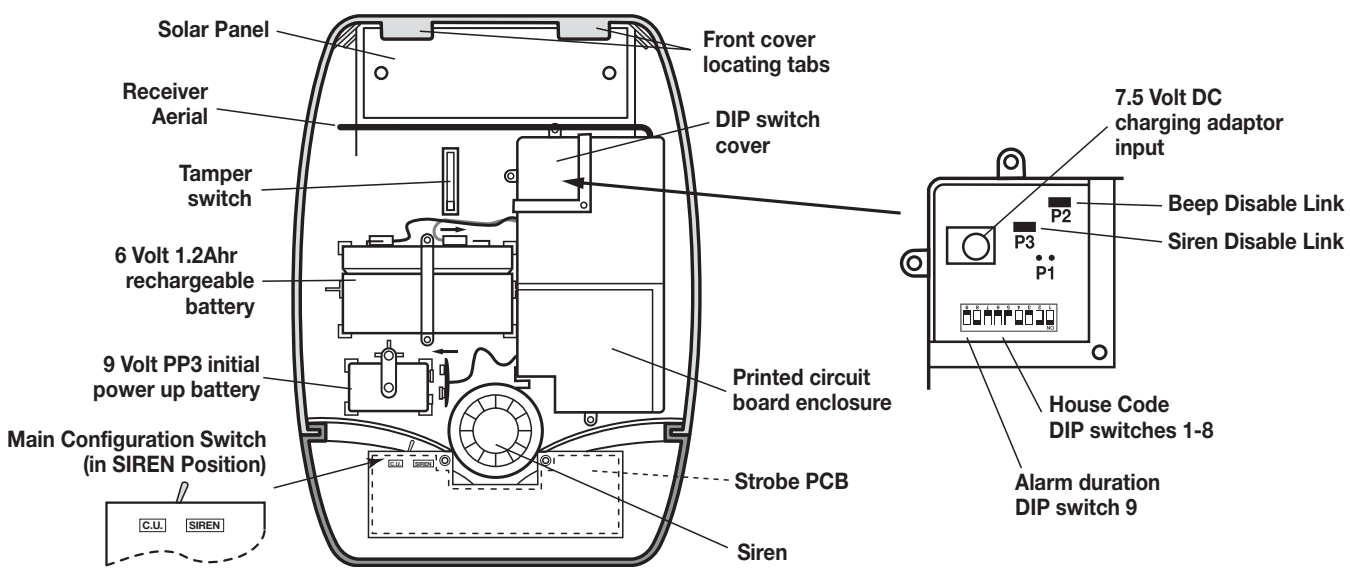

11. The Solar Siren will acknowledge Disarm signals from the Remote Control and Service Mode signals from the Control Panel by beeping. It is possible to disable these acknowledgement beeps if required by removing the jumper link P2 on the circuit board.

P2 fitted	beep enabled
P2 removed	beep disabled

12. If for any reason you need to disable the Siren, remove jumper link P3 on the circuit board. This will prevent the Siren from sounding during an alarm condition. However, the Siren will still beep to acknowledge signals from the Remote Control, (provided the beep feature is not disabled).

P3 fitted	Siren enabled
P3 removed	Siren disabled

13. Refit the DIP switch cover and replace the three cover fixing screws. Do not over tighten the screw as this could damage the thread.

## POWER-UP OF THE SOLAR SIREN

1. Connect the 9V PP3 initial power battery to the battery clip.

Connect the rechargeable battery to the charging leads. Connect the Red lead to the Red (+ve) terminal and the Black lead the Black (-ve) terminals.

**IMPORTANT:** Once the batteries have been connected, the Siren will be operational and it is important that the solar panel receives sufficient light to maintain the battery charge. The Siren should not be operated repeatedly during installation and testing, as this will rapidly drain the battery. It is recommended that the Siren be left for at least a day in order to charge the battery before the system is Armed.

2. Press the anti-tamper switch, the LEDs will flash together to indicate that the unit is operational.

3. Hinge the front cover locating tabs over the top edge of the back plate and carefully push the base of the siren cover into place. Secure the Siren cover in place by refitting the fixing screw in the bottom edge of the cover. Do not over tighten the screw as this could damage the thread.

**IMPORTANT:** Ensure that the rear tamper switch is closed when you fit the siren cover to the back-plate (i.e. listen for the switch to click). If the switch does not close this will prevent the Solar Siren from operating correctly. If necessary, remove the siren cover again and adjust the screw on the back-plate tamper plunger to ensure the switch closes when the Siren is secured in position.

4. If fitted remove the protective film covering the Solar Panel.

## TESTING THE SOLAR SIREN

**Ensure that the system is in Test mode, (see page 18).**

1. Press  on the Control Panel.

The Control Panel alarm and Solar Siren will operate for a period of approximately 5 seconds with the Solar Siren switching ON and OFF a few seconds after the Control Panel.

**Note:** To stop the siren test before the 5s period has elapsed press  on the Control Panel.

# EXTERNAL CONNECTIONS

The Control Unit incorporates a terminal block for connection of an external Hard-wired Siren or Telephone Dialler unit. The connection terminal block is located inside the Control Panel behind the front cover.

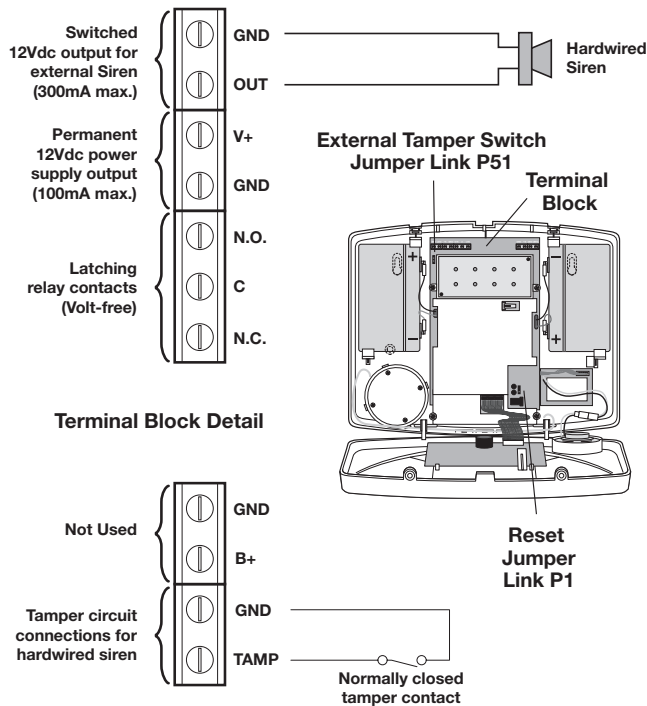

To access the terminal block, press



This puts the system into Test Mode and prevents an alarm occurring. Undo the two fixing screws on the top edge of the Control Panel and open the front cover.

Before making any connections, ensure that the memory jumper link P1 is in the 'OFF' position and then remove the DC power jack and disconnect the back-up batteries.

**Note:** Jumper link P51 should be fitted into the ON position only if the tamper circuit for a hardwired siren is used, otherwise it must be in the OFF position.

After making your external connections reconnect the power supply and Back-up Battery. Then close the Control Panel cover and tighten the fixing screws on the top edge of the Control Panel.

Press to leave Test mode and return to Standby.

# TESTING THE SYSTEM

## INITIAL TESTING

As the system is initially installed it is recommended that each device is tested in turn as it is installed, (refer to testing instructions for particular device).

## TESTING AN INSTALLED SYSTEM

The Control Panel has a programmed test routine. You may test the system at any time, however it is recommended that the system is tested at regular intervals not exceeding 3 months.

With the system in Standby Mode with the Power LED ON.



The Arm and Part-Arm LEDs will flash.

The system is now in the Test Mode

**Note:** After completing all required test functions press to leave Test mode and return to Standby.

## DETECTOR TEST

Before commencing testing please ensure that there is no movement in any PIR protected area, all doors/windows protected by Magnetic Contact Detectors are closed and that all battery covers are correctly fitted.

Press

Zone LED 1 will illuminate.

Trigger each detector on the system by either walking into a PIR protected area or by opening a door/window protected by a Magnetic Contact detector. As each detector is triggered the Control Panel will beep and the LED of the zone which the detector is configured for will be illuminated. The Tamper switches of devices may also be tested in the same way in which case the Tamper Led on the Control Panel will be illuminated.

Press to exit detector test

## HARD-WIRED SIREN TEST

Press **2**

The internal relay driving the hardwired siren will be switched ON for a period of approximately 5 seconds. Zone LED 2 will be illuminated during the test.

## SIREN TEST

Press **3**

The Control Panel alarm and the External Solar Siren will be operated for a period of approximately 5 seconds with the external Solar Siren switching ON and OFF a few seconds after the Control Panel.

Zone LED 3 will be illuminated during the test.

## CONTROL PANEL LED TEST

Press **4**

Zone LED 4 will illuminate.

Use **↑** and **↓** buttons to scroll through and illuminate each LED in turn.

Press **ESC** to exit LED test.

## SOLAR SIREN SERVICE MODE

In order to remove the Solar Siren from the wall to change the batteries. It is necessary to place the Siren into Service mode to prevent the Tamper protection on the Siren operating and triggering the siren.

Press **5** to switch the Solar Siren between Service Mode and normal Operating Mode.

**Service Mode:** The Solar Siren will produce two short beeps followed by a single long beep 10 seconds later to indicate that it has switched into service mode.

**Operating Mode:** After 10 seconds the Solar Siren will produce one long beep followed immediately by two short beeps to indicate that it has switched into normal operating mode.

**IMPORTANT:** After changing the batteries and refitting in position, the Solar Siren must be put back into normal Operating Mode, otherwise the siren will not sound in the event of an alarm condition.

## VOICE DIALLER TEST

Press **6**

Zone LED 6 will illuminate.

The voice dialler will call each activate number in the dialling sequence in turn set number of times. When a call is answered the recorded alarm message will be replayed for the set Message Play Time. If the call is unanswered or an acknowledgment signal is not received from the number called, (i.e. by pressing the **\*** button on the telephone keypad) the next number in the sequence will be called.

Press **ESC** to exit voice Dialler test.

## FACTORY DEFAULTS

User Access Code:	1 2 3 4
Alarm Duration:	3 minutes
Hardwired Siren:	Equal to Alarm Duration
Zone Operating Mode:	Zones 1-6: Intruder
Part-Arm:	Zones 1, 5, 6: Disabled Zones 2, 3, 4: Active
Instant/Delay:	Zone 1: Delay Zones 2-6: Instant
Entry/Exit Delay:	30s
Entry/Exit Warning Tone:	On
Zone Lockout:	On
Jamming Detection:	Off
Phone Numbers:	Not programmed
Message Play Time:	70s
Alarm Message:	Not programmed
Call Routing:	All numbers disabled
Call Attempts:	3
Dial Method:	Tone/DTMF

## RESET FACTORY DEFAULT CONDITIONS

1. Press **🔒**, **?**, **?**, **?**, **?**, **ENTER**  
*User Access Code*

to place the system in Test Mode.

2. Undo the Control Panel cover fixing screws and open the cover.

3. Switch OFF the mains supply to the plug-in PSU Adapter and remove the plug from the DC power socket in the Control Panel.
4. Remove either back-up battery and disconnect the battery leads.
5. Set jumper link P1 to the ON position.

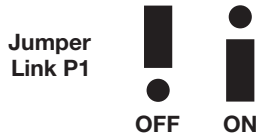

6. Reconnect the battery leads and replace the back-up battery in position.
7. The Control Panel will now reconfigure itself with all factory default settings. This takes approximately 10 seconds.
8. Reconnect the PSU Adaptor plug to the DC power socket in the Control Panel and switch On the supply to the PSU Adaptor.
9. Reset jumper link P1 into the OFF position.
10. Close the Control Panel cover and refit the fixing screws.

## PROGRAMMING INSTRUCTIONS

With the system in Standby Mode with the Power LED ON.

Press  ,     , 

*User Access Code*

The Arm and Part-Arm LEDs will illuminate and all Zone, Fire and tamper LEDs will flash.

### The system is now in the Programming Mode

**Note:** After programming all required functions press  to leave Programming mode and return to Standby.

## USER ACCESS CODE

Default setting: 1 2 3 4

Press  , 

Zone LEDs 1-4 will illuminate.

Enter a new 4 digit User Access code. As each digit is entered an illuminated zone LEDs will be turned OFF.

Press  to save the new User Access code and return to programming mode.

Press  to return to programming mode without saving.

## SYSTEM HOUSE CODE

Press  , 

The Zone LEDs 1-6, Fire and Tamper LEDs will illuminate to display the current House Code setting with an illuminated LED indicating a setting of "1" in the House Code, LEDs which are OFF indicate a "0".

### For example:

A house code of 11110010, will be indicated with zone LEDs 1-4 ON and 5-6 OFF, Fire LED ON and Tamper LED OFF.

### a) At the Control Panel:

By pressing buttons 1-8 on the Control Panel, configure the status LEDs so that they indicate the required house code setting. The LEDs will switch to the opposite state each time the button is pressed.

LED ON = 1, (House Code DIP Switch On/Up)  
LED OFF = 0, (House Code DIP Switch Off/Down)

Press  to save the new setting and return to programming mode.

Press  to return to programming mode without saving.

### b) Using a Remote Control:

With the required House Code already configured, press the DISARM button on the Remote Control.

The Control Panel will beep twice to acknowledge the signal.

The Zone, Fire and Tamper LED status will be updated to correspond with the House Code set on the Remote Control and now programmed into the Control Panel.

Press  to return to programming mode.

## INSTANT/DELAY ZONES

Default setting: zone 1: Delay, zones 2-6: Instant

Press  , 

The zone LEDs corresponding to the zones currently set to Delay will be illuminated. LEDs for zones set to Instant will be OFF.

LED ON	Delay Zone
LED OFF	Instant Zone

To change the settings of a zone press the button corresponding to the zone number. The zones will switch to the opposite mode each time the button is pressed.

Press  to save the new setting and return to programming mode.

Press  to return to programming mode without saving.

## ENTRY/EXIT DELAY

Default setting: 30 seconds

Press  , 

The zone LED corresponding to the current setting will illuminate.

0	no delay, (i.e. Instant)
1	10 seconds
2	20 seconds
3	30 seconds
4	40 seconds
5	50 seconds

Press the key corresponding to the required delay setting, the corresponding zone LED will illuminate as the setting is changed.

Press  to save the new setting and return to programming mode.

Press  to return to programming mode without saving.

## ALARM DURATION

Default setting: 3 minutes

Press  , 

The zone LED corresponding to the current setting will illuminate.

0	no alarm
1	1 minute
2	2 minutes
3	3 minutes
4	5 minutes
5	10 minutes

Press the key corresponding to the required alarm period, the corresponding zone LED will illuminate as the setting is changed.

**Note:** When set to 'No alarm' the Siren will sound for approximately 10s if an alarm condition is initiated.

Press  to save the new setting and return to programming mode.

Press  to return to programming mode without saving.

**Note:** Following initiation of a Full Alarm condition the External Siren will continue to sound until either the system is Disarmed; or the Control Panel Alarm Duration Time expires; or if activated until the 3 minute alarm time limit of the external Siren expires; whichever occurs first.

## PART-ARM

Default setting: zone 1: Disabled, zones 2-6: Active

Press  , 

The zone LEDs corresponding to the zones currently active during Part-Arm mode will be illuminated. LEDs for zones disabled during PART-ARM will be OFF.

LED ON	Zone enabled in Part-Arm
LED OFF	Zone disabled in Part-Arm

To change the setting of a zone press the button corresponding to the zone number. The zone will toggle between the two modes each time the button is pressed.

Press  to save the new setting and return to programming mode.

Press  to return to programming mode without saving.

## ZONE LOCKOUT

This feature, if enabled, prevents a single zone from triggering an alarm condition more than three times before the system is disarmed. However, if disabled there is no limit on the number of times a zone can trigger an alarm condition.

Default setting: ON

Press **7** , 

The zone 1 LED will illuminate to indicate the current Zone Lockout status.

LED ON	Zone Lockout enabled
LED OFF	Zone Lockout disabled

Press **1** to change the setting to the opposite state.

Press  to save the new setting and return to programming mode.

Press  to return to programming mode without saving.

## ENTRY/EXIT WARNING TONE

Default setting: ON

Press **8** , 

The zone 1 LED will illuminate to indicate the current status of the Entry/Exit warning tone.

LED ON	Tone enabled
LED OFF	Tone disabled

Press **1** to change the setting to the opposite state.

Press  to save the new setting and return to programming mode.

Press  to return to programming mode without saving.

## JAMMING DETECTION

This feature controls the Control Panels RF jamming detection circuitry, which if enabled, will continuously scan for radio jamming signals on the system operating frequency.

Default setting: OFF

Press **9** , 

The zone 1 LED will illuminate to indicate the current Jamming Detector status.

LED ON	Jamming Detection enabled
LED OFF	Jamming Detection disabled

Press **1** to change the setting to the opposite state.

Press  to save the new setting and return to programming mode.

Press  to return to programming mode without saving.

**Note:** It is recommended to run the system for 30 days before setting up the jamming detection system if required.

## HARDWIRED SIREN

Default setting: equal to Alarm Duration

Press **1** **0** , 

The zone LED corresponding to the current setting will illuminate.

1	2 seconds
2	30 seconds
3	1 minute
4	3 minutes
5	5 minutes
6	equal to Alarm Duration

Press the key corresponding to the required Hardwired output activation period, the corresponding zone LED will illuminate as the setting is changed.

Press  to save the new setting and return to programming mode.

Press  to return to programming mode without saving.

## ZONE OPERATING MODES

Each alarm zone may be programmed to operate in one of 5 different modes dependant upon the type of alarm function it is required to perform.

### Personal Attack

- used to provide 24 hour monitoring of any Personal Attack (PA) switches fitted to the system. Activation of any PA switch will immediately initiate a Full Alarm condition.



### Intruder

- provides standard intruder monitoring with normal ARM and PART-ARM functions.

### 24 Hour Intruder

- used to provide 24 hour monitoring of areas requiring continuous security protection even while the system is Disarmed, (e.g. gun lockers). Activation of any detector on a security zone will immediately initiate a Full Alarm condition.

### Fire

- use to provide 24 hour monitoring of any Fire/Smoke detectors fitted to the system. Activation of any detector will immediately initiate a Full Alarm condition.

### Test

- when the system is armed, any detector on the zone will cause the appropriate zone LED on the Control Panel to flash without initiating a Full Alarm condition.

**Note:** Personal Attack, 24 Hour Intruder and Fire modes all operate on a 24 hour basis, (i.e. they are able to initiate Full Alarm condition at any time irrespective of whether the system is Armed or Disarmed).

Default setting: all zones mode 2 (Intruder).

Press **1 1** ,  to configure zone 1

Press **1 2** ,  to configure zone 2

Press **1 3** ,  to configure zone 3

Press **1 4** ,  to configure zone 4

Press **1 5** ,  to configure zone 5

Press **1 6** ,  to configure zone 6

The zone LED corresponding to the current operating mode will illuminate.

Zone 1 LED	Personal Attack (PA)
Zone 2 LED	Intruder
Zone 3 LED	24 Hour Intruder
Zone 4 LED	Fire
Zone 5 LED	Test

Enter the key corresponding to the required operating mode, the corresponding zone LED will illuminate as the setting is changed.

Press  to save the new setting and return to programming mode.

Press  to return to programming mode without saving.

## TELEPHONE NUMBERS

Default setting: not programmed (all numbers).

Press **1 7** ,  to program phone number 1

Press **1 8** ,  to program phone number 2

Press **1 9** ,  to program phone number 3

Press **2 0** ,  to program phone number 4

Enter the new phone number (32 digits max).

**Note:** Press  to insert a 3.5s pause in the number when dialled.

Press  to save the new number and return to programming mode.

Press  to return to programming mode without saving.

## ALARM MESSAGE PLAY TIME

This is the total time for which the alarm messages will be played & repeated when a call made by the voice dialler is answered.

Default setting: 70s

Press **2 1** , 

The zone LED corresponding to the current setting will illuminate.

Zone 1 LED	50s
Zone 2 LED	70s
Zone 3 LED	90s
Zone 4 LED	110s

Enter the key corresponding to the required message play time, the corresponding zone LED will illuminate as the setting is changed.

Press  to save the setting and return to programming mode.

Press  to return to programming mode without saving.

## RECORD ALARM MESSAGE

Default setting: not programmed

Press **2** **2** , 

The zone 1 LED will illuminate.

Press  to start the voice recorder.

Zone LED 1 will flash while recording. The maximum allowable length of the alarm message is 32s. After this period the Panel will beep twice to indicate that the recording has stopped and returned to programming mode.

Alternatively press  to stop the recorder before the max 32s and cancel any unused message time.

## REPLAY ALARM MESSAGE

The recorded alarm message may be replayed and listened to using the telephone handset of a phone connected to another extension socket on the same phone line.

Press **2** **3** , 

The zone 1 LED will illuminate.

Pick up the telephone handset and press  to stop the dialing tone.

Press  to start replaying the recorded alarm message.

Zone LED 1 will flash while the alarm message is being replayed. At the end of the message the Panel will beep twice and returned to programming mode.

Alternatively press  to stop replaying the message before the end and return to programming mode.

## CALL ROUTING

This controls which telephone numbers are enabled in the dialling sequence and are dialled when the voice dialler is activated.

Default setting: All numbers inactive

Press **2** **4** , 

Zone LEDs 1-4 will be illuminated to indicate the active status of telephone numbers 1-4 in the routing sequence. LEDs for telephone numbers disabled will be OFF.

LED ON	Telephone number enabled
LED OFF	Telephone number disabled

To change the active status of a phone number press the button corresponding to the phone number. The LED will toggle between states each time the button is pressed.

Press  to save the new number and return to programming mode.

Press  to return to programming mode without saving.

## CALL ATTEMPTS

This sets the maximum number of times that the dialler will attempt to contact each enabled phone number in the call routing sequence.

Default setting: 3

Press **2** **5** , 

The zone LED corresponding to the current setting will illuminate.

Zone 1 LED	1 attempt
Zone 2 LED	2 attempts
Zone 3 LED	3 attempts
Zone 4 LED	4 attempts
Zone 5 LED	5 attempts

Press the key corresponding to the required number of dialling attempts, the corresponding zone LED will illuminate as the setting is changed.

Press  to save the new setting and return to programming mode.

Press  to return to programming mode without saving.

## DIAL METHOD

This enables the telephone dialler to be configured for the type of exchange it is connected to.

**Note:** Most installations withn the UK are now operating on a Tone/DTMF based exchange.

Default setting: Tone/DTMF

Press **2** **6** , 

The zone LED corresponding to the current setting will illuminate.

1	Tone/DTMF
2	Pulse

Press the key corresponding to the required dial method, the corresponding zone LED will illuminate as the setting is changed.

Press  to save the new setting and return to programming mode.

Press  to return to programming mode without saving.

## OPERATING INSTRUCTIONS

When leaving the premises, the system must be Armed. However, before doing so, check that all windows are closed and locked, all protected doors are closed and PIR Movement Detectors are not obstructed. Ensure that pets are restricted to areas not protected by PIR Movement Detectors.

The system has two armed modes, ARM and PART-ARM. The Part-Arm facility allows for selected zones to be left in a Disarmed state whilst the remainder of the system is Armed.

When the system is Armed (in either mode) the Zone LEDs for all active zones will illuminate for a few seconds, in addition the appropriate Arming Mode LED will flash. All active zones set as INSTANT will immediately be fully Armed. If enabled the System Exit delay will start and the Control Panel will start beeping with the beep rate increasing in steps as the delay expires. At the end of the Exit period all active zones set to DELAY will be fully Armed. By this time the user must have left the property and closed the final protected door.

If while the system is armed a detector on an INSTANT zone is triggered then this will immediately initiate a Full Alarm condition with both Control Panel and Siren sounding. However if a detector on a DELAY zone is triggered, if enabled, the Entry Delay will start and the Control Panel will start beeping with the beep rate increasing in steps as the delay expires. If the system has not been Disarmed when the Entry Delay expires a Full Alarm condition will be initiated. If a Full Alarm condition occurs the appropriate zone LED that triggered the alarm will flash to indicate which zone the alarm was triggered from. If an alarm condition occurs the zone that triggered the alarm will be indicated by the appropriate zone LED on the Control Panel being illuminated.

At the end of the programmed alarm duration the Siren and Control Panel alarms will stop and the system will automatically re-Arm itself, (subject to the conditions of the Zone Lockout feature).

**Note:** The Solar Siren will shut down either after the programmed alarm duration or after 3 minutes, if the 3 minute limit has been enabled on the Solar Siren.

## ARMING THE SYSTEM

### ARM

The system can be set in ARM mode using either the Remote Control or the Control Panel as follows:

#### Remote Control:

Press the  button,

The Control Panel will acknowledge the signal by beeping.

#### Control Panel:

Press the Arm button followed by the User Access Code and then the Enter button:



*User Access Code*

The Control Panel will acknowledge the signal by beeping.

### PART-ARM

The system can be set in PART-ARM mode using either the Remote Control or the Control Panel as follows:

#### Remote Control:

Press the  button,

The Control Panel will acknowledge the signal by beeping.

#### Control Panel:

Press the Part-Arm button followed by the User Access Code and then the Enter button



*User Access Code*

The Control Panel will acknowledge the signal by beeping.

## DISARMING THE SYSTEM

The system can be Disarmed using either the Remote Control or the Control Panel as follows:

#### Remote Control:

Press the  button,

The Control Panel will acknowledge the signal by beeping.

The Siren will also acknowledge the Disarm signal beeping twice unless beep disable has been set.

#### Control Panel:

Press the 'Disarm' key, followed by the current User Access code followed by the 'Enter button



User Access Code

The Control Panel will acknowledge the signal by beeping.

If the system has been triggered and an alarm condition has occurred, then the appropriate LED will be illuminated to indicate which zone(s) have triggered the alarm. Make a note of the zone(s) indicated to assist in tracing the cause of the alarm, before pressing  to clear the indication and return the system to Standby.

## PERSONAL ATTACK (PA) ALARM

A full Alarm condition can be immediately initiated at any time (whether the system is Armed or Disarmed) in the event of threat or danger by activating a Personal Attack (PA) switch on either the Remote Control or the Control Panel.

#### Remote Control:

Slide the Personal Attack switch upwards

#### Control Panel:

Press and hold the  button for approximately 3 seconds.

The alarm will continue either for the alarm duration when the system will automatically reset or until the system is disarmed.

## TAMPER

If the battery cover of any device (except a Remote Control) is removed or if the Siren or Control Panel are removed from the wall then a Full Alarm condition will be initiated even if the system is Disarmed. The alarm condition will continue either for the alarm duration when the system will automatically reset or until the system is Disarmed from the Remote Control or Control Panel. The Tamper LED on the Control Panel will flash to indicate the Tamper Alarm has been activated.

**Note:** The Tamper protection facility on the Siren operates independently of the Control Panel. If the Tamper on the Siren is activated this will not be indicated at the Control Panel.

## SIREN SERVICE MODE

In order to remove the Solar Siren from the wall to change the batteries, it is necessary to place the Siren into Service mode to prevent the Tamper switch on the Siren operating and triggering an alarm. When you have completed any alterations to the system remember to switch the siren back into Operating mode.

The siren can be switched into service mode using either the Remote Control or Control Panel as follows:

#### Remote Control:

Press and hold the  button for approximately 6 seconds.

The Siren will produce two short beeps as the button is pressed followed by a single long beep approximately 6 seconds later to indicate that it has switched into service mode.

#### Control Panel:

With the system in Standby with the Power LED ON:

Press  ,  ,  ,  ,  , 

User Access Code

to enter Test mode. The Arm and Part-Arm LEDs will flash.

Press  to switch the Siren between Service mode and Operating Mode. LED 5 will illuminate to show that the appropriate signal is being transmitted.

The Siren will produce two short beeps as the button is pressed followed by a single long beep approximately 6 seconds later to indicate that it has switched into service mode.

Press  to return to Standby mode.

## SIREN OPERATING MODE

The siren can be switched back into operating mode using either the Remote Control, Control Panel as follows:

### Remote Control:

Press and hold the  button for approximately 6 seconds.

After approximately 6 seconds the Siren will produce a single long beep to indicate that it has switched into operating mode in a Disarmed state. The button must be released during or immediately after the long beep, otherwise the system will switch into an Armed state.

### Remote Control:

With the system in Standby with the Power LED ON:

Press , , , , ,   
*User Access Code*

to enter Test mode. The Arm and Part-Arm LEDs will flash.

Press  to switch the Siren between Service mode and Operating mode. LED 5 will illuminate to show that the appropriate signal is being transmitted.

After approximately 6 seconds the Siren will produce a single long beep to indicate that it has switched into operating mode in a Disarmed state.

Press  to return to Standby mode.

## BATTERY MONITORING

All system devices continuously monitor their battery condition. The Control Panel also monitors the battery condition of all PIR and Magnetic detectors. If the battery level of any device drops below acceptable levels then its low battery indication will be activated.

In addition if any PIR or Magnetic Contact detector has a low battery status it will be indicated on the 'LOW BAT' LED on the Control Panel.

LED ON	Magnetic Contact
LED Flashing	PIR

When a low battery indicator is activated the device will continue to operate normally for up to 2 weeks (depending upon system use). However, the battery for that device should be replaced as soon as possible.

**Note:** Before removing the battery cover on any device to replace the battery ensure that the system is put into Test mode to avoid initiating a Full Alarm condition.

The low battery indication for each system component is as follows:

### Remote Control

When the Remote Control is operated under low-battery conditions the transmit LED will continue to flash after the button has been released.

Under normal battery conditions the LED will extinguish when the button is released.

### PIR Movement Detector

Under low battery conditions the LED behind the detector lens will flash when movement is detected to indicate that the battery needs to be replaced.

Under normal battery conditions the LED does not illuminate unless the PIR detector is in Walk Test mode.

### Magnetic Contact Detector

Under low battery conditions, when the Detector is activated, the transmit LED will be illuminated for approximately 1s as the door/window is opened.

Under normal battery conditions the LED will not illuminate as the Detector is operated, (unless the Detector is in Test Mode with the battery cover removed).

# MAINTENANCE

Your Alarm System requires very little maintenance. However, a few simple tasks will ensure its continued reliability and operation.

**IMPORTANT:** Should you, for any reason, have to completely power-down the system (e.g. to move the system to a new premises) first put the system into Test mode before removing the Control Panel cover and disconnecting the power supply and back-up batteries. To power-down the Siren, undo the fixing screw on the bottom edge and remove the front cover. As the cover is removed the Siren's Tamper switch will activate, immediately cancel the alarm using the Remote Control. Disconnect both the rechargeable battery and initial power-up battery and ensure that the solar panel is covered with a light proof material to prevent it being energised.

## SOLAR SIREN

1. It is recommended that the Solar Panel on the top of the siren housing should be cleaned at least twice a year, preferably in the Spring and Autumn, using a soft damp cloth. Do not use abrasive, solvent based or aerosol cleaners. Do not attempt to clean inside the unit or allow water to enter the unit.

This will ensure that the Solar Panel does not become affected by the build up of excessive dirt and receives all the available light.

2. The Solar Siren should not be left for long periods with the batteries connected, unless the unit is able to receive sufficient light to maintain the battery charge. Failure to maintain charge to the unit will result in the rechargeable battery running unacceptably low. Should this occur, the unit must be recharged from a 7.5Vdc/100mA supply (e.g. from a mains adaptor power supply). When re-powering the Solar Siren fit a new 9V PP3 leak proof Alkaline power-up battery to ensure that the Unit receives sufficient power until the solar panel can recharge the main battery.
3. The main rechargeable battery has a typical life of 3- 4 years and needs no maintenance during this period, provided the battery is kept charged.

The battery will be damaged if it is stored in a discharged state for long periods.

**Note:** Before removing the Solar Siren from the wall, either to replace the batteries or for any other reason, ensure that the Solar Siren is first switched into Service Mode to prevent the tamper protection switch activating the Siren, (see page 17). After replacing the batteries ensure that the siren is switched back into normal operating mode.

## CONTROL PANEL

The rechargeable batteries have a typical life of 3 – 4 years and need no maintenance during this period, provided they are kept charged. The batteries will be damaged if they are stored in a discharged state for long periods.

## DETECTORS AND REMOTE CONTROL

The Detectors require very little maintenance. The batteries should be replaced once a year or when a low battery status is indicated.

## BATTERIES

Before removing the battery cover on any device or opening the Control Panel to replace the battery ensure that the system is put into Test mode to avoid initiating a Full Alarm condition.

The specifications for replacement batteries are as follows:

Remote Controls:	1 x 3V CR2032 Lithium Cells (or equivalent)
Magnetic Contact Detectors:	2 x 3V CR2032 Lithium Cells (or equivalent)
PIR Movement Detectors:	1 x 9V PP3 Alkaline

**Note:** Where applicable only fit PP3 Alkaline type batteries. Rechargeable batteries should NOT be fitted.

At the end of their useful life the batteries should be disposed of via a suitable Recycling Centre. Do not dispose of with your normal household waste. DO NOT BURN.

The Rechargeable Batteries contain Sulphuric Acid - DO NOT ATTEMPT TO OPEN THE CASING.

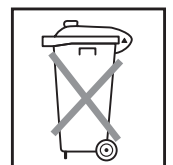

**Pb**

# ALARM RECORD

Complete the following information during installation for future reference when adding to your system and to assist Trouble Shooting Zone Settings.

			Zone Settings			
Zone	Detector Type(s)	Location(s)	Zone Operating Mode	Instant / Delay	Arm	Part-Arm
1						
2						
3						
4						
5						
6						

You may make a note of your User Access Codes and Installer Access Code below.

### User Access Code

---

### System House Code

ON

1

2

3

4

5

6

7

8

Use the above diagram to record your House Code e.g.  = ON

### Voice Dialler Phone Numbers

Phone Number 1 .....

Phone Number 2 .....

Phone Number 3 .....

Phone Number 4 .....

***This information is confidential and should be kept in a safe location.***

# TROUBLE SHOOTING

<b>Symptom / Recommendation</b>	<b>Symptom / Recommendation</b>
<p><b>Control Unit not working – Power LED OFF.</b></p> <ol style="list-style-type: none"> <li>1. Mains power failure - check if other electrical circuits are operable.</li> <li>2. Check that mains adaptor is plugged in and socket is switched ON.</li> <li>3. Check that DC jack plug from mains adaptor is connected in Control Panel.</li> <li>4. Check fuse/MCB in Consumer Unit on the circuit serving the Control Panel.</li> </ol> <p><b>Note:</b> Before replacing any fuses or resetting the MCB, the cause of the failure should be investigated and rectified.</p>	<p><b>Detection Zone triggered (LED flashing) but no alarm is sounding.</b></p> <ol style="list-style-type: none"> <li>1. Entry/Exit delay still running and not yet expired.</li> <li>2. Alarm duration period has already expired and system has reset.</li> <li>3. Alarm duration programmed to "no alarm".</li> </ol>
<p><b>Control Unit "Low Battery" LED flashing.</b></p> <ol style="list-style-type: none"> <li>1. Check all PIR movement Detectors for low battery indication, (i.e. LED behind detection lens flashes when movement detected). Renew batteries as required.</li> </ol>	<p><b>Siren and Strobe operating but no alarm at Control Panel.</b></p> <ol style="list-style-type: none"> <li>1. Siren Tamper switch activated. Check security of Siren fixing to wall and adjustment of anti-tamper switch to ensure switch is fully depressed.</li> <li>2. Siren Jamming detection circuit operated, (jamming detection at Control Panel disabled).</li> </ol>
<p><b>Control Unit "Low Battery" LED illuminated.</b></p> <ol style="list-style-type: none"> <li>1. Check all Magnetic Contact Detectors for low battery indication, (i.e. LED on Detector body illuminates for 1s when detector triggered). Renew batteries as required.</li> </ol>	<p><b>Siren not responding to Control Panel.</b></p> <ol style="list-style-type: none"> <li>1. Ensure that the 'House Code' is correctly set.</li> <li>2. Ensure main Siren configuration switch is set to SIREN.</li> <li>3. Incorrect User Access code being entered at Control Panel.</li> <li>4. Ensure Siren is within effective radio range of Control Panel and equipment is not mounted close to metal objects.</li> <li>5. Siren rechargeable battery discharged               <ol style="list-style-type: none"> <li>a. Clean Solar Panel.</li> <li>b. Check age of rechargeable battery – replace if at end of useful life.</li> <li>c. Fit new initial power-up battery and re-power up siren.</li> </ol> </li> </ol>
<p><b>Control Unit not accepting User Access code.</b></p> <ol style="list-style-type: none"> <li>1. Pause between key depressions too long. Do not pause for more than 5 seconds between pressing keys.</li> <li>2. Incorrect code entered. Allow 5 seconds to elapse before re-entering correct code.</li> <li>3. Reset to factory defaults and reprogram system.</li> </ol>	<p><b>Full Alarm Condition occurs when system has not been triggered by an intruder or is disarmed.</b></p> <ol style="list-style-type: none"> <li>1. Tamper switch activation               <ol style="list-style-type: none"> <li>a. check all detector battery covers to ensure correctly fitted.</li> <li>b. check Control Panel and Siren are securely mounted to the wall and tamper switch is closed.</li> </ol> </li> <li>2. Personal Attack Alarm operated from a Remote Control or Control Panel.</li> <li>3. Jamming detection circuit operated.</li> </ol>
<p><b>Control Unit not responding to detectors.</b></p> <ol style="list-style-type: none"> <li>1. Ensure that the 'House Code' is correctly set.</li> <li>2. Ensure detector is within effective radio range of Control Panel and equipment is not mounted close to metal objects.</li> <li>3. Detector battery low - Replace detector battery.</li> </ol>	



# TROUBLE SHOOTING - continued

<b>Symptom / Recommendation</b>	<b>Symptom / Recommendation</b>
<p><b>LED on Remote Control not illuminating, or is dim when unit is operated.</b></p> <ol style="list-style-type: none"> <li>1. Ensure battery is connected with correct polarity.</li> <li>2. Ensure battery connections are good.</li> <li>3. Replace battery.</li> </ol>	<p><b>Magnetic Contact Detector not working.</b></p> <ol style="list-style-type: none"> <li>1. Ensure batteries are connected with correct polarity.</li> <li>2. Ensure battery connections are good.</li> <li>3. Ensure 'House Code' is correctly set.</li> <li>4. Ensure DIP switches 9, 10 and 11 are set correctly.</li> <li>5. Ensure detector is within effective radio range of Control Panel and is not mounted close to metal objects which may interfere with RF transmission.</li> <li>6. If an additional Magnetic Contact Detector is not connected ensure jumper link fitted.</li> <li>7. If additional Magnetic Contact Detector is connected:               <ol style="list-style-type: none"> <li>a. Ensure jumper link removed.</li> <li>b. Check that additional contact is correctly wired.</li> <li>c. Ensure that magnet is correctly positioned in relation to detector and that the gap between magnet and detector is not too large, (refer to instruction supplied with external Magnetic Contact detector).</li> </ol> </li> </ol> <p><b>Note:</b> If an additional contact is used then the doors/windows protected by both the main wirefree detector and the additional wired detector must be closed when either is opened. If one of the doors/windows is already open then the opening of the other door/window will not be detected.</p>
<p><b>PIR Movement Detector false alarming.</b></p> <ol style="list-style-type: none"> <li>1. Ensure that the detector is not pointing at a source of heat or a moving object.</li> <li>2. Ensure that the detector is not mounted above a radiator or heater.</li> <li>3. Ensure that the detector is not facing a window or in direct sunlight.</li> <li>4. Ensure that the detector is not in a draughty area.</li> <li>5. Pulse count set too low – reset to two pulse detection.</li> </ol>	<p><b>Magnetic Contact Detector false alarming</b></p> <ol style="list-style-type: none"> <li>1. Ensure that magnet is correctly positioned in relation to detector</li> <li>2. Ensure that gap between magnet and detector is less than 10mm.</li> <li>3. Tamper switch below battery cover not depressed - check battery cover is fitted correctly and that fixing lugs are not broken.</li> </ol>
<p><b>PIR Movement Detector not detecting a person's movement.</b></p> <ol style="list-style-type: none"> <li>1. Check battery connections are good.</li> <li>2. Pulse count set too high - reset to one pulse detection.</li> <li>3. Check that the detector is correctly set up. (See PIR Movement Detectors pages 9-11).</li> <li>4. Ensure DIP switches 1- 4 of SW3 are correctly set.</li> <li>5. Ensure that detector is mounted the correct way up, (i.e. with detection window at the bottom).</li> <li>6. Ensure that the detector is mounted at the correct height, (i.e. 2-2.5m).</li> <li>7. Allow up to three minutes for detector to stabilise.</li> <li>8. Ensure detector is within effective radio range of Control Panel and is not mounted close to metal objects which may interfere with RF transmission.</li> </ol>	<p><b>LED on Magnetic Contact Detector illuminating when door or window is opened</b></p> <ol style="list-style-type: none"> <li>1. Low battery - replace Batteries.</li> </ol>
<p><b>PIR Movement Detector LED flashes on detection of movement, (device in normal operation mode).</b></p> <ol style="list-style-type: none"> <li>1. Low battery - replace battery.</li> </ol>	

## TROUBLE SHOOTING - continued

<b>Symptom / Recommendation</b>	<b>Symptom / Recommendation</b>
<p><b>Voice Dialler Not Operating.</b></p> <ol style="list-style-type: none"> <li>1. Check that phone line is operating normally by connecting a normal telephone to the socket that the Control Panel is plugged into and checking for a dialling tone.</li> <li>2. Check Control Panel is connected to telephone socket using lead supplied.</li> <li>3. Voice Dialler not configured correctly               <ol style="list-style-type: none"> <li>a. Phone number(s) incorrectly programmed.</li> <li>b. Phone number(s) not enabled in Call Routing sequence.</li> <li>c. Alarm Message has not been recorded.</li> <li>d. Dial method incorrectly set for type of exchange, (i.e. Tone/DTMF or Pulse).</li> </ol> </li> </ol>	

<p><b>IF YOU HAVE ANY PROBLEMS RING THE HELPLINE:</b></p> <h1 style="margin: 0;">0845 373 1353</h1> <p><b>(Lines open 9.00am to 5.00pm, Monday to Friday.)</b></p>	
<p><b>Important notice following alarm installation:</b></p>	<p>In order to comply with the Code of Practice on Noise from Intruder Alarms 1981 you should carry out the following procedures within 48 hours of Intruder Alarm installation.</p> <ol style="list-style-type: none"> <li>1. Notify your local police station in writing that an Intruder Alarm System has been installed, giving names and contact details of at least two persons who have a Remote Control or know the User Access code for the Control Panel.</li> <li>2. Inform the Local Environmental Health Authority of the installation and which police station has been informed.</li> <li>3. Ensure that all users are aware of the operating procedures.</li> <li>4. Immediately inform your Local Authority and police station if there is a change to the persons who have Remote Controls.</li> </ol>

# EXTENDING YOUR ALARM SYSTEM

Your system may be extended to provide additional protection by adding additional PIR Movement Detectors, Magnetic Contact Sets and Remote Control Units.

## ACCESSORIES

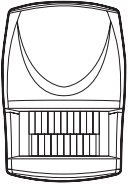

### SA433P

Wirefree Passive Infra-Red Detector

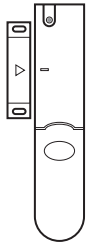

### SA433M

Wirefree Magnetic Contact Detector

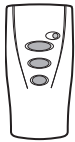

### SA433R

Remote Control

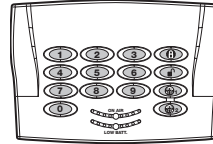

### SA433KP

10 Digit Keypad

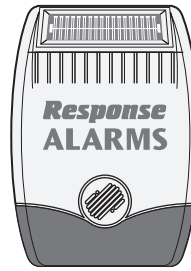

### SA433SS

Additional Solar Siren

---

## GUARANTEE

We undertake to replace or repair at our discretion goods (excluding non rechargeable batteries) should they become defective within 1 year solely as a result of faulty materials and workmanship.

Understandably if the product has not been installed, operated or maintained in accordance with the instructions, has not been used appropriately or if any attempt has been made to rectify, dismantle or alter the product in any way the guarantee will be invalidated.

The guarantee does not extend to cover consequential loss or damage or installation costs arising from the defective product. This guarantee does not in any way affect the statutory or other rights of a consumer and applies to products installed within the UK and Eire only.

If an item develops a fault, the product must be returned to the point of sale with:

1. Proof of purchase.
2. A full description of the fault.
3. All relevant batteries (disconnected).

Friedland is a trade mark of Novar ED&S.

Novar Electrical Devices  
and Systems are  
Quality Assurance Registered  
to BS EN ISO9001 1994,  
by Asta.

# COMPONENT SPECIFICATION

## External Solar Siren

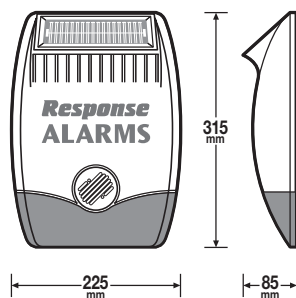

- RF operating frequency: 433MHz
- Sealed lead acid battery 6V/1.2Ahr
- Solar Panel 7.5V - Charge Rate typically 60mA
- Operation time in complete darkness – up to 25 days
- Instant alarm mode
- 15s Entry/Exit Delay alarm mode
- High power piezo siren
- Switchable Alarm Duration: 1 and 3 minutes
- Auto reset on activation
- Siren Disable (selectable)
- Dual front and rear anti-tamper protection
- Jamming Detection
- Audible confirmation (selectable)

## LED Control Panel with Voice Dialler

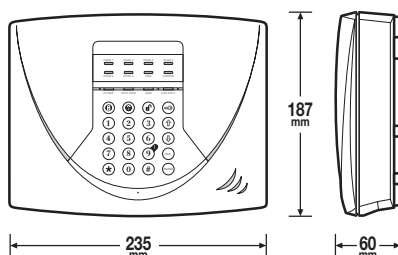

- RF operating frequency: 433MHz
- Range: 50m
- Battery Back-up
- Detector Battery Status Indication
- Telephone Voice Dialler – 30s recordable alarm message – Rings up to 4 telephone numbers
- 6 Zones
- Part-Arm Facility
- Instant or Delayed Alarm Zones
- Programmable Entry/Exit Delay
- Entry/Exit Delay Warning (selectable)
- Internal piezo siren
- Connections for Hardwired Siren and External Voice Dialler
- Programmable 4 digit User Access Code
- Programmable Alarm Duration
- Auto Reset
- Zone Lockout
- Siren Disable (selectable)
- Dual front and rear anti-tamper protection
- Personal Attack (PA)
- Jamming Detection

## Remote Control (available separately)

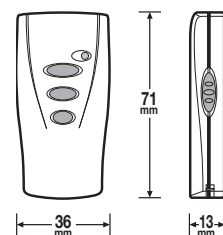

- RF operating frequency: 433MHz
- Range: 50m max.
- Personal Attack (PA) switch
- Operates all Arm, Part-Arm and Disarm functions
- Transmission indicator
- Typical battery life > 1 year
- Low battery Indicator

## Passive Infra-Red Movement Detector(s)

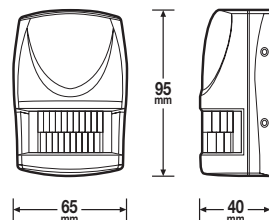

- RF operating frequency: 433MHz
- Range: 75m max.
- Detection range: up to 12m at 110° and 6m at 180°
- Walk test facility
- One or two pulse count detection
- Anti-Tamper protection
- Corner or surface mount
- Typical battery life > 1 year
- Low battery Indicator

## Magnetic Contact Detector(s)

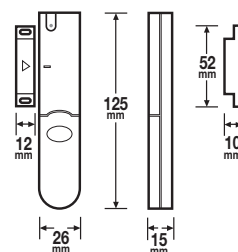

- RF operating frequency: 433MHz
- Range: 75m max.
- Test Mode
- Anti-Tamper protection
- Facility to add external wired Magnetic Contacts or Personal Attack buttons
- Battery Life >1 year
- Low Battery Indicator

### RESEARCH & DEVELOPMENT

Our R & D Department is constantly developing new products. We practice a policy of continued improvement and reserve the right to change specifications without prior notice.

**If you need help,  
just dial the  
Helpline for expert  
technical support**

**HELPLINE:  
0845 373 1353**

(Lines open 9.00am to 5.00pm,  
Monday to Friday).



**Response Electronics Ltd.**

Roman House, Lysons Avenue, Ash Vale, Surrey GU12 5QF

Distributors for Friedland Wireless Alarm Products.